

## Signet 2450 Pressure Sensor



3-2450.090-1 Rev. 12 10/17

### Product Manual



### Description

The 2450 Pressure Sensor has a one-piece injection molded PVDF body and ceramic diaphragm for superior compatibility in corrosive liquids. These sensors are available with Digital (S<sup>3</sup>L) output or field-scaleable 4 to 20 mA output. Select from three (3) pressure ranges for optimal measurement resolution. Built-in temperature compensation provides outstanding accuracy over a wide operating range. Versions with 1/2 in. union process connection are best suited for in-line installations. Integral adapters (sold separately) may be used to create a compact assembly with field mount versions of the 9900 Transmitter.

### Dimensions

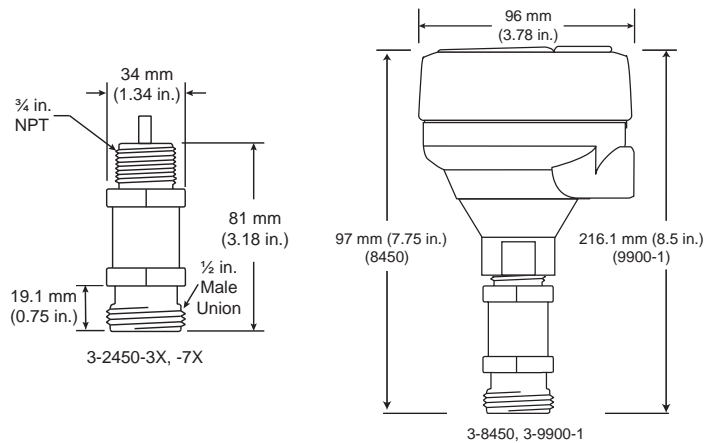

- [English](#)
- [Deutsch](#)
- [Français](#)
- [Español](#)



## Warranty Information

Refer to your local Georg Fischer Sales office for the most current warranty statement.

All warranty and non-warranty repairs being returned must include a fully completed Service Form and goods must be returned to your local GF Sales office or distributor. Product returned without a Service Form may not be warranty replaced or repaired.

Signet products with limited shelf-life (e.g. pH, ORP, chlorine electrodes, calibration solutions; e.g. pH buffers, turbidity standards or other solutions) are warranted out of box but not warranted against any damage, due to process or application failures (e.g. high temperature, chemical poisoning, dry-out) or mishandling (e.g. broken glass, damaged membrane, freezing and/or extreme temperatures).

## Product Registration

Thank you for purchasing the Signet line of Georg Fischer measurement products.





If you would like to register your product(s), you can now register online in one of the following ways:

- Visit our website [www.gfsignet.com](http://www.gfsignet.com). Under **Service and Support** click on **Product Registration Form**
- If this is a pdf manual (digital copy), [click here](#)

## Safety Information

1. Prior to installation or removal:
  - Depressurize and vent system
  - Drain below sensor level
2. Confirm chemical compatibility before use.
3. Do not exceed maximum temperature/pressure specifications.
4. Wear safety goggles or faceshield during installation/service.
5. Do not alter product construction.
6. Dispose of properly; **DO NOT INCINERATE!**

**USE THE ATTACHED ADHESIVE LABEL TO PRESERVE THE SAFETY INSTRUCTIONS!**

|   |   |
|---|---|
|  | <b>Caution / Warning / Danger</b><br>Indicates a potential hazard. Failure to follow all warnings may lead to equipment damage, injury, or death  |
|  | <b>Personal Protective Equipment (PPE)</b><br>Always utilize the most appropriate PPE during installation and service of Signet products.   |
|  | <b>Pressurized System Warning</b><br>Sensor may be under pressure, take caution to vent system prior to installation or removal. Failure to do so may result in equipment damage and/or serious injury. |
|  | <b>Hand Tighten Only</b><br>Overtightening may permanently damage product threads and lead to failure of the retaining nut.   |
|  | <b>Do Not Use Tools</b><br>Use of tool(s) may damage product beyond repair and potentially void product warranty.   |

## Specifications

### General

|   |  |
|---|--|
| Compatibility                           |  |
| Digital (S <sup>3</sup> L) models ..... | 8900, 9900, 9950                                   |
| 4 to 20 mA models .....                 | PLC  |
| Wetted materials                        |  |
| Sensor housing .....                    | PVDF   |
| Diaphragm .....                         | Ceramic  |
| Seal .....                              | FKM  |
| Process connection                      |  |
| -3X, -7X .....                          | 1/2 in. Union male thread,<br>where X = U, L, or H |
| Rear connection .....                   | 3/4 in. NPT male thread                            |
| Cable type .....                        | 3 cond + shield, 22 AWG                            |
| Standard cable length                   |  |
| -3X, -7X .....                          | 4.6 m (15 ft)                                      |
| Sensor Accuracy .....                   | ±1% of full scale @ 25 °C                          |
| Thermal sensitivity shift .....         | ±0.03% of full scale per °C                        |
| Shipping weight .....                   | 0.3 kg (0.65 lb.)                                  |

### Electrical

|  |  |
|--|--|
| Power Requirements   |  |
| Digital (S <sup>3</sup> L) models .....                      | 5 to 6.5 VDC ±10%, <1.5 mA                           |
| 4 to 20 mA models .....                                      | 12 to 24 VDC ±10% regulated                          |
| Short circuit & reverse polarity protected                   |  |
| Digital (S <sup>3</sup> L) output                            |  |
| Type .....   | Serial ASCII, TTL level 9600 bps                     |
| Accuracy .....   | ±1% of full scale @ 25 °C                            |
| Repeatability .....  | ±0.5% of full scale                                  |
| Resolution .....   | 0.01 psi (0.001 psi for -XU)                         |
| Update rate .....  | <100 ms  |
| 4 to 20 mA output  |  |
| Accuracy .....   | ±32 µA   |
| Repeatability .....  | ±0.5% of full scale                                  |
| Resolution .....   | <5 µA  |
| Span .....   | Field-scaleable<br>(see page 6 for factory settings) |
| Max loop impedance .....                                     | 100 Ω @ 12 V<br>325 Ω @ 18 V<br>600 Ω @ 24 V         |
| Update rate .....  | <100 ms  |
| Operating range (Max. pressure for accuracy specifications): |  |
| -XU .....  | 0 to 0.7 bar (0 to 10 psig)                          |
| -XL .....  | 0 to 3.4 bar (0 to 50 psig)                          |
| -XH .....  | 0 to 17.2 bar (0 to 250 psig)                        |

### Vacuum range

|           |   |
|-----------|---|
| -XU ..... | -0.1 to 0.7 bar<br>(-1.5 to 10 psi)     |
| -XL ..... | -0.41 to 3.4 bar<br>(-6 to 50 psi)      |
| -XH ..... | -0.96 to 17.2 bar<br>(-14.6 to 250 psi) |

### Proof pressure

(Max. pressure without damage)

|           |                        |
|-----------|------------------------|
| -XU ..... | 1.4 bar<br>(20 psig)   |
| -XL ..... | 5.2 bar<br>(75 psig)   |
| -XH ..... | 20.7 bar<br>(300 psig) |

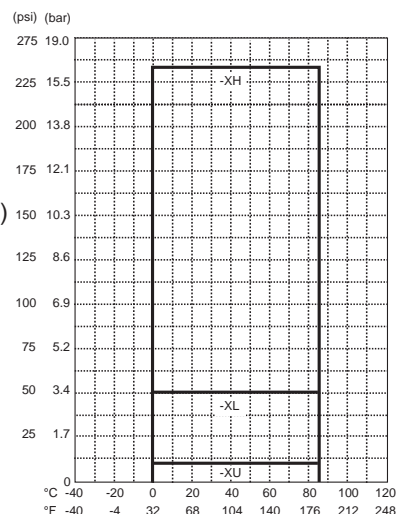

## Specifications

### Environmental

Relative humidity ..... 0 to 95%  
 (Non-condensing)  
 Storage temperature..... -20 °C to 100 °C (-4 °F to 212 °F)  
 Operating temperature ..... -15 °C to 85 °C (5 °F to 185 °F)

### Standards and Approvals

CE  
 RoHS Compliant  
 Manufactured under ISO 9001 for Quality, ISO 14001 for Environmental Management and OHSAS 18001 for Occupational Health and Safety.

 China RoHS (Go to [www.gfssignet.com](http://www.gfssignet.com) for details)

 Declaration of Conformity according to FCC Part 15:

This device complies with Part 15 of the FCC rules.  
 Operation is subject to the following two conditions:  
 (1) This device may not cause harmful interference, and,  
 (2) This device must accept any interference received, including interference that may cause undesired operation.

## Installation

Signet 2450 Pressure Sensors are gauge pressure sensors. Gauge pressure sensors measure the difference in pressure between the process on one side of a diaphragm and the atmospheric pressure on the opposite side of the diaphragm. A tiny capillary tube inside the sensor body is used to ensure that the back of the diaphragm remains at atmospheric pressure. If moisture is allowed to propagate down this tube to the rear of the diaphragm, the sensor may be damaged.

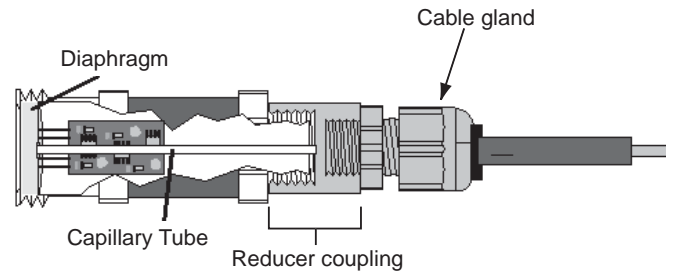

### Important Installation Recommendations

- The ceramic diaphragm is subject to breakage by over-pressure conditions or mechanical contact. **HANDLE WITH CARE.** Do not attempt to test the sensor by pressing on the diaphragm.
- Short duration pressure pulses or shocks, called “water hammer,” are generated by a rapid change in flow rate caused by the operation of system components such as compressors, pumps, pistons and valves. Water hammer can reach pressure levels far exceeding the over pressure rating of our pressure sensors and damage the ceramic diaphragm.
- A pressure snubber is a device for slowing the rate of change of system flow. Installation of a properly sized snubber at or near the input of a pressure sensor will protect it from water hammer damage. Snubbers are available through plumbing and instrumentation dealers.
- When threading the sensor into a piping system, any backpressure can damage the ceramic diaphragm. Open nearby valves to relieve any backpressure while threading the sensor into the pipe.
- If the nearby valves cannot be open while threading the sensor into the pipe, a bleed valve can be installed to avoid overpressure.
- Make sure there are no air bubbles in the pipe, particularly if a long and flexible hose is used to tap into the process pipe. Air bubbles could cause reading fluctuation and errors.

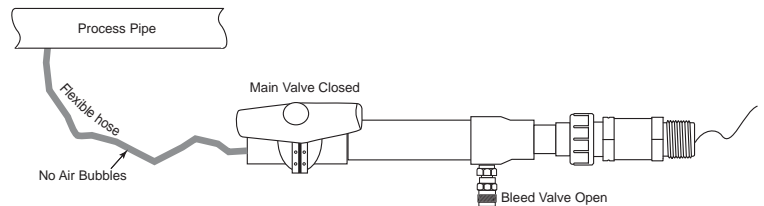

## Installation

### Integral Assembly Sensor Modification

- Modify sensor part number 3-2450 per figure 1.
- Apply sealant or PTFE tape to the process connection threads per figure 2, after inspecting threads to ensure integrity. Do not install a sensor with damaged threads.
- Thread the sensor into the 3-8052 mounting kit.
- Tighten the sensor 1½ turns past finger tight into the process connection.
- Install 9900 transmitter (refer to 9900 manual for wiring info) with Angle Adjustment Adapter.
- The 3-8052 Integral kit includes:
  - 3-9000.392-1 liquid tight connector, ½ in. NPT
  - Conduit base to attach 9900.

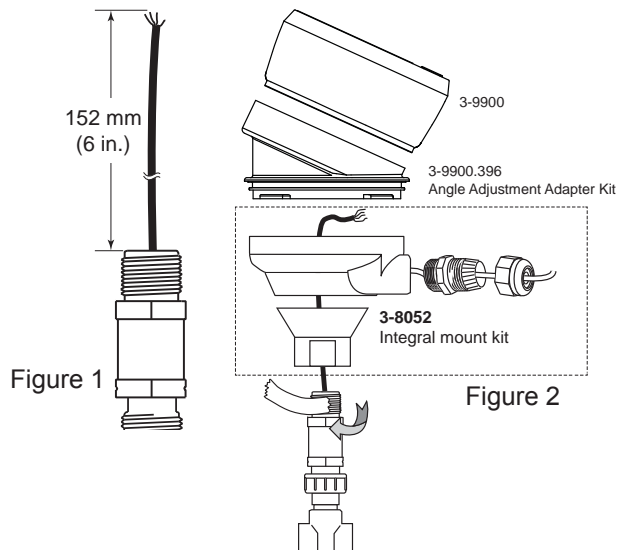

### Tank Installation Options

#### Submersible:

- Refer to the GF product 3-2250-XX for submersible installations.

#### Side Tank Mount:

- Install GF ball valve to allow isolation of the sensor for maintenance.
- It is recommended that a 3-8052-1 kit be used to protect the back end of the sensor.

**WARNING:** Exposing the sensor body to elevated temperatures that are different than the tank fluid temperatures will cause inaccurate reading.

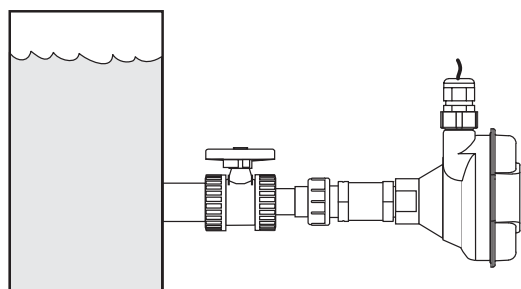

## Installation

### In-line Remote Assembly

The optional 3-8052-1 Integral Junction box with ¾ in. process connection offers a convenient terminal point to extend the 2450 cable over a distance greater than 4.6 m (15 ft).

- The kit includes:
  - Conduit base and cap with junction terminals
  - 3-9000.392-1 liquid tight connector, ½ in. NPT
- To extend the wires longer than 4.6 m (15 ft):
  - Modify sensor 3-2450 as described in figure 1.
  - Terminate the three wires to the terminal board located in the cap assembly.
  - Add customer supplied wire to extend the cable.
  - Terminate to the transmitter or the 4 to 20 mA input device.
  - Apply sealant or PTFE tape to the process connection threads per figure 3, after inspecting threads to ensure integrity. Do not install a sensor with damaged threads.
  - Tighten the sensor 1½ turns past finger tight into the process connection.

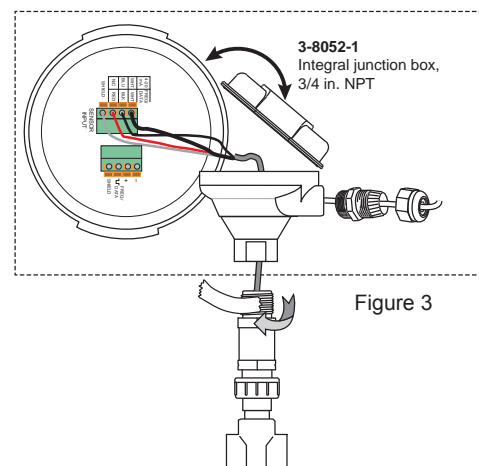

### 1/2 Inch Male Union Installation

The 2450-3X and the 2450-7X sensors have a union-style process connection. To assemble:

1. Slide union nut onto pipe or flexible tubing.
2. Install end connectors.
3. Hand-tighten union nut to secure.

Refer to Signet Measurement and Instrumentation Product Catalogue for ordering information.

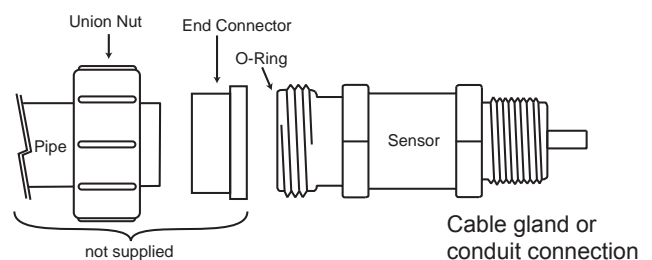

## Wiring

### Digital (S<sup>3</sup>L) wiring

- All models of the 2450 provide Digital (S<sup>3</sup>L) output when powered with 5 VDC.
- Connecting the SHIELD to a direct earth ground may reduce electrical noise interference.
- The maximum Digital (S<sup>3</sup>L) cable length is dependent upon the instrument to which the sensor is connected.

Consult the instrument manual for wiring details.

- Connect the 2450 cable directly to Digital (S<sup>3</sup>L) I/O terminals.

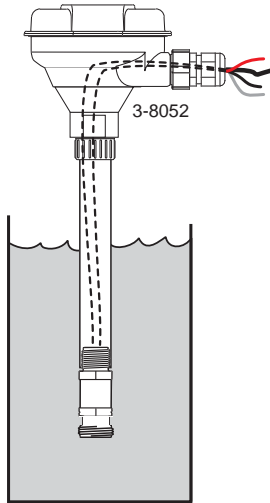

#### 3-9900 S<sup>3</sup>L connector

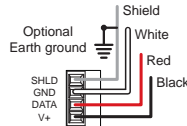

#### 3-8900 I/O Module Connector

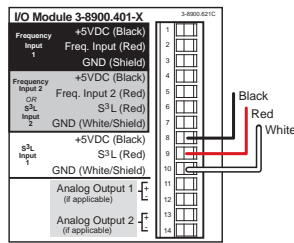

#### 3-9950 S<sup>3</sup>L connector

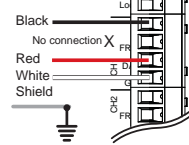

- When the 2450 includes a junction box, connect the 2450 terminals to any Digital (S<sup>3</sup>L) I/O port as shown.

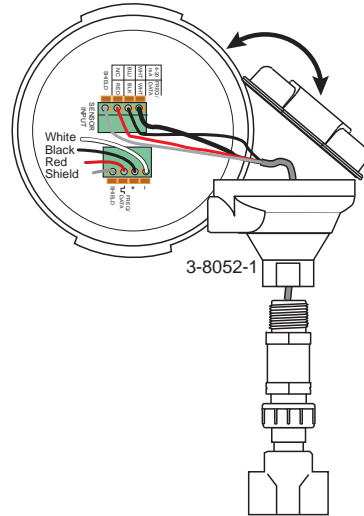

### 4 to 20 mA Loop Wiring

- The 2450-7X models provide a 4 to 20 mA loop output when powered with 24 VDC.
- Connecting the SHIELD to a direct Earth ground may reduce electrical noise interference.
- Red wire is not used, do not remove the heat shrink. See page 6, 4 to 20 mA Span Adjustment.

#### Current Loop With No Junction Box

- Connect the 2450 cable directly to a loop device as shown.

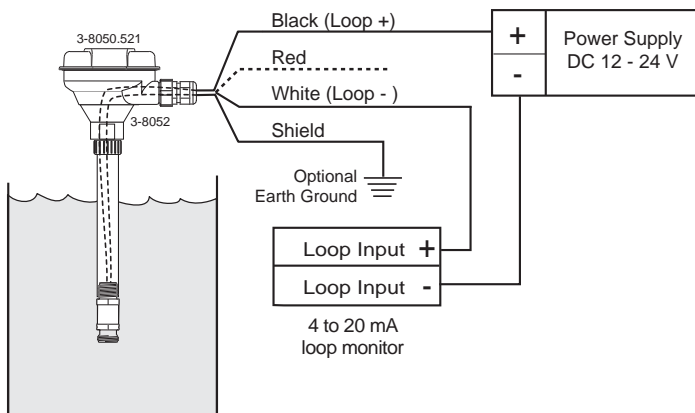

#### Current Loop With Junction Box

- When the 2450 includes a junction box, connect the 2450 terminals to the loop device as shown.

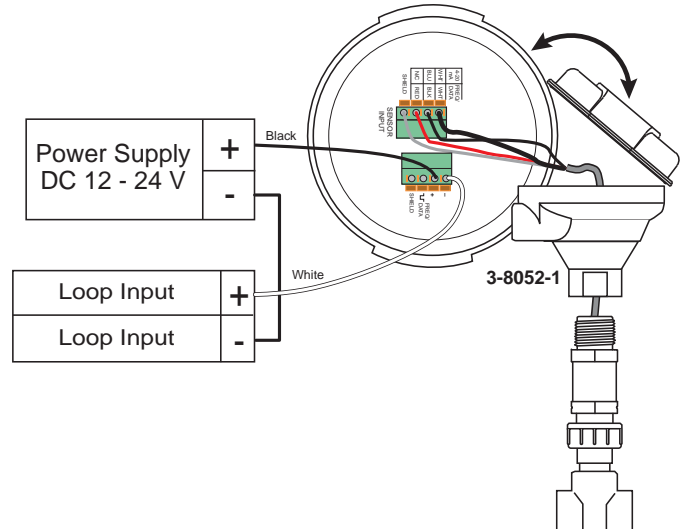

## 4 to 20 mA Span Adjustment

The 4 to 20 mA endpoint values are independent of one another and may be adjusted in the field. For example, to reduce the 20 mA endpoint value from the maximum full scale limit set at the factory, but to allow the 4 mA endpoint to remain at 0 psig, perform only the steps listed below.

**NOTE:** The RED wire, which is not connected during normal 4 to 20 mA operation, assumes an important role in the following procedures.



### WARNING!

Not protecting the red wire may cause the 4 to 20 mA span to be reset.

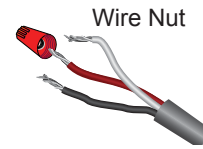

### To adjust the 4 mA endpoint in the field:

- Carefully remove the heat shrink tube that is protecting the red wire.
- Expose the sensor to the pressure desired to correspond with 4 mA (any pressure in the operating range).
- With power applied as described on page 5, connect the RED wire to the WHITE wire for 15 seconds.  
(After about 10 seconds the output will drop to 3.6 mA and remain there until the RED wire is disconnected.)
- Disconnect the RED wire from the WHITE wire; the 4 mA endpoint has been adjusted.

**NOTE:** The output will act as a switch if the 4 and 20 mA endpoints are set very near to the same value.

### To adjust the 20 mA endpoint in the field:

- Expose the sensor to the pressure desired to correspond with 20 mA (any pressure in the operating range).
- With power applied as described on page 5, connect the RED wire to the BLACK wire for 15 seconds.  
(After about 10 seconds the output will rise to 22 mA and remain there until the RED wire is disconnected.)
- Disconnect the RED wire from the BLACK wire; the 20 mA endpoint has been adjusted.

**NOTE:** The output will act as a switch if the 4 and 20 mA endpoints are set very near to the same value.

Minimum span is  $\pm 2\%$  of maximum range.

- After adjusting the 4 to 20 mA span, protect the red wire by installing the provided wire nut.
- For easier re-spanning use the Signet 0252 Configuration Tool.

### To restore factory span:

- Disconnect power to the sensor. Wait 10 seconds to allow circuit to discharge.
- Connect the RED wire to the WHITE wire.
- Apply power as described on page 5, but with the RED wire connected to the WHITE wire for 15 seconds.  
(After about 10 seconds the output will drop to 3.6 mA and remain there until the RED wire is disconnected.)
- Disconnect the RED wire from the WHITE wire; factory settings have been restored.
- Replace cap on RED wire.

| Mfr. Part No. | Factory Span               |
|---------------|----------------------------|
| 3-2450-7U     | 4 to 20 mA = 0 to 10 psig  |
| 3-2450-7L     | 4 to 20 mA = 0 to 50 psig  |
| 3-2450-7H     | 4 to 20 mA = 0 to 250 psig |

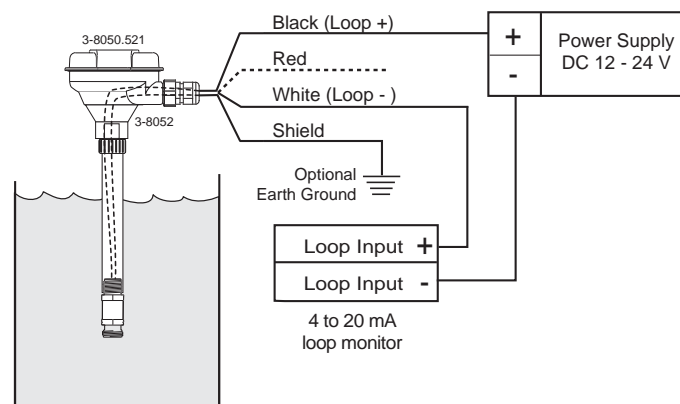



## Ordering Information

| Mfr. Part No. | Code        | Description   |
|---------------|-------------|---|
| 3-2450-3U     | 159 000 683 | 10 psig, Digital (S <sup>3</sup> L), 1/2 in. Male Union, 15 ft Cable  |
| 3-2450-7U     | 159 000 906 | 10 psig, 4 to 20 mA, 1/2 in. Male Union, 15 ft Cable                  |
| 3-2450-3L     | 159 000 682 | 50 psig, Digital (S <sup>3</sup> L), 1/2 in. Male Union, 15 ft Cable  |
| 3-2450-7L     | 159 000 908 | 50 psig, 4 to 20 mA, 1/2 in. Male Union, 15 ft Cable                  |
| 3-2450-3H     | 159 000 681 | 250 psig, Digital (S <sup>3</sup> L), 1/2 in. Male Union, 15 ft Cable |
| 3-2450-7H     | 159 000 910 | 250 psig, 4 to 20 mA, 1/2 in. Male Union, 15 ft Cable                 |
| 3-8050-1      | 159 000 753 | Universal Mount Junction Box  |
| 3-8052-1      | 159 000 755 | 3/4 in. NPT mount junction box  |
| 3-9000.392-1  | 159 000 839 | Liquid tight connector kit, NPT (1 piece)                             |
| 3-9000.392-2  | 159 000 841 | Liquid tight connector kit, PG 13.5 (1 piece)                         |
| 3-9900.396    | 159 001 701 | Angle Adjustment Adapter Kit  |
| 5523-0322     | 159 000 761 | Cable, 3 conductor + shield, 22 AWG, black/red/white/shield           |
| 3-0252        | 159 001 808 | Configuration Tool  |



Georg Fischer Signet LLC, 3401 Aero Jet Avenue, El Monte, CA 91731-2882 U.S.A. • Tel. (626) 571-2770 • Fax (626) 573-2057  
For Worldwide Sales and Service, visit our website: [www.gfsignet.com](http://www.gfsignet.com) • Or call (in the U.S.): (800) 854-4090  
For the most up-to-date information, please refer to our website at [www.gfsignet.com](http://www.gfsignet.com)