

Signet 2250 Hydrostatic Level Sensor



3-2250.090 Rev. 5 10/17

Product Manual



Description

The Signet 2250 Hydrostatic Level Sensor uses a gauge pressure sensor to calculate the level of fluid in a tank.

Gauge pressure sensors measure the difference in pressure between the process on one side of a diaphragm and the atmospheric pressure on the opposite side of the diaphragm. A tiny capillary tube running from inside the sensor body and up the length of the cable provides the reference to atmospheric pressure.

Hydrostatic level measurement can be a simple and practical solution to those applications where the fluid temperature is stable and constant.



IMPORTANT!

This method of level measurement is not recommended if the fluid is subject to temperature variations or any other variable that causes the density of the fluid to change.

The 2250 Hydrostatic Level Sensor has excellent chemical compatibility. The wetted materials are PVDF, Ceramic and FKM.

Several different hardware mounting kits are available to accommodate every installation requirement.

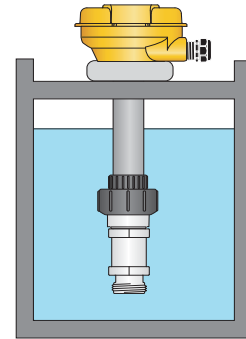

Table of Contents

- Warranty Statement..... 2
- Product Registration 2
- Safety Information..... 2
- Dimensions 2
- Specifications..... 3
- Installation..... 3
- 2250 Assembly Detail 4
- Wiring..... 5-6
- Respanning the 4 to 20 mA Output..... 7
- Ordering Information..... 8



- [English](#)
- [Deutsch](#)
- [Français](#)
- [Español](#)
- [Italiano](#)



Warranty Information

Refer to your local Georg Fischer Sales office for the most current warranty statement.

All warranty and non-warranty repairs being returned must include a fully completed Service Form and goods must be returned to your local GF Sales office or distributor. Product returned without a Service Form may not be warranty replaced or repaired.

Signet products with limited shelf-life (e.g. pH, ORP, chlorine electrodes, calibration solutions; e.g. pH buffers, turbidity standards or other solutions) are warranted out of box but not warranted against any damage, due to process or application failures (e.g. high temperature, chemical poisoning, dry-out) or mishandling (e.g. broken glass, damaged membrane, freezing and/or extreme temperatures).

Product Registration







Thank you for purchasing the Signet line of Georg Fischer measurement products.

If you would like to register your product(s), you can now register online in one of the following ways:

- Visit our website www.gfsignet.com. Under **Service and Support** click on **Product Registration Form**
- If this is a pdf manual (digital copy), [click here](#)

Safety Information

1. Prior to installation or removal:
 - Depressurize and vent system
 - Drain below sensor level
2. Confirm chemical compatibility before use.
3. Do not exceed maximum temperature/pressure specifications.
4. Wear safety goggles or faceshield during installation/service.
5. Do not alter product construction.
6. Dispose of properly; DO NOT INCINERATE!

	Caution / Warning / Danger Indicates a potential hazard. Failure to follow all warnings may lead to equipment damage, injury, or death
	Electrostatic Discharge (ESD) / Electrocutation Danger Alerts user to risk of potential damage to product by ESD, and/or risk of potential of injury or death via electrocution.
	Personal Protective Equipment (PPE) Always utilize the most appropriate PPE during installation and service of Signet products.
	Pressurized System Warning Sensor may be under pressure, take caution to vent system prior to installation or removal. Failure to do so may result in equipment damage and/or serious injury.
	Hand Tighten Only Overtightening may permanently damage product threads and lead to failure of the retaining nut.
	Do Not Use Tools Use of tool(s) may damage product beyond repair and potentially void product warranty.

Specifications

General

Compatibility Signet 8900 Multi-Parameter Controller
Signet 9900 Transmitter
Signet 9950 Dual Channel Transmitter

Wetted Material

Sensor housing PVDF
Union nut/bushing PVC-U
Diaphragm Ceramic
Diaphragm seal FKM (optional EPDM)
Cable type 22 AWG, 3 conductor+capillary tube
Cable length 10 m (32.8 ft) supplied
max. extension 120 m (400 ft)
Operating Temperature 15 °C to 85 °C (5 °F to 185 °F)
Storage Temperature -20 °C to 100 °C (-4 °F to 212 °F)
Operating Pressure: -XU: 0 to 0.7 bar (0 to 10 psig)
-XL: 0 to 3.4 bar (0 to 50 psig)

Electrical

Digital (S³L) Output
Format Serial ASCII, TTL level 9600 bps.
Accuracy ±1% of full scale (±0.001 psi)
Power 5 VDC nominal, 1.5 mA max. current
(5 VDC min, 6.5 VDC max)
Reverse polarity and short circuit protected

4 to 20 mA Output

Factory span
-XU 0 to 0.7 bar (0 to 10 psig) =
0 m to 7 m (0 ft to 23 ft) of water
-XL 0 to 3.4 bar (0 to 50 psig) =
0 m to 34 m (0 ft to 115.5 ft) of water
Accuracy ± 32 µA
Resolution < 5 µA
Response Time < 100 ms
Loop Power Required 12 to 24 VDC nominal, 22.1 mA max
(10.8 VDC min. to 26.4 VDC max.)
Max. Loop Impedance 100 Ω @ 12 V
325 Ω @ 18 V
600 Ω @ 24 V

Standards and Approvals

CE
RoHS Compliant
Manufactured under ISO 9001 for Quality, ISO 14001 for Environmental Management and OHSAS 18001 for Occupational Health and Safety.

 China RoHS (Go to www.gfsignet.com for details)

 This device complies with Part 15 of the FCC rules.

Operation is subject to the following two conditions:

- (1) This device may not cause harmful interference, and,
- (2) This device must accept any interference received, including interference that may cause undesired operation.

Dimensions

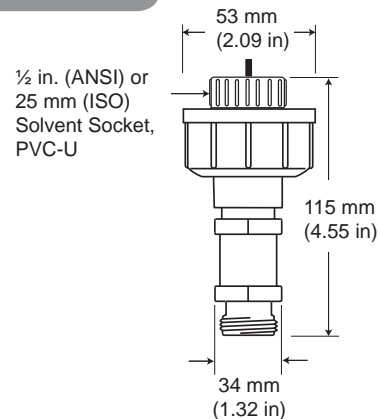

Installation



IMPORTANT!

A tiny capillary tube inside the sensor body is used to ensure that the back of the diaphragm remains at atmospheric pressure.

If the capillary tube is blocked or damaged, the sensor cannot operate properly.

- If moisture is allowed to propagate down this tube to the rear of the diaphragm, the sensor may be damaged.
- Do not allow the cable to be bent or compressed.
- The ceramic diaphragm in the 2250 can be permanently damaged by over-pressure conditions or by mechanical contact.

HANDLE THESE SENSORS WITH CARE.

Direct 4 to 20 mA output

The 2250 can be assembled as a blind 4 to 20 mA signal connected by cable to a PLC, chart recorder or other 4 to 20 mA device.

This type of installation requires no additional hardware.

The user must provide the 3/4 in. conduit to protect the cable from damage. The 2250 cable is not suitable for direct submersion.

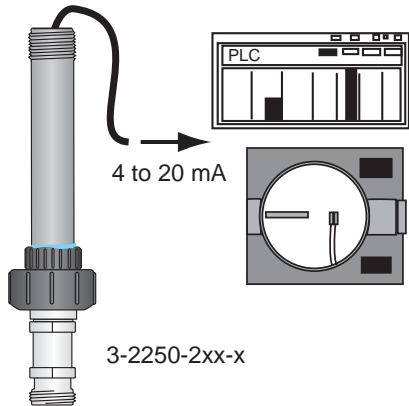

Direct Digital output

The 2250 can be assembled as a digital sensor connected directly to a Signet 8900 Multi-Parameter Controller, a Signet 9900 Transmitter or Signet 9950 Dual Channel Transmitter

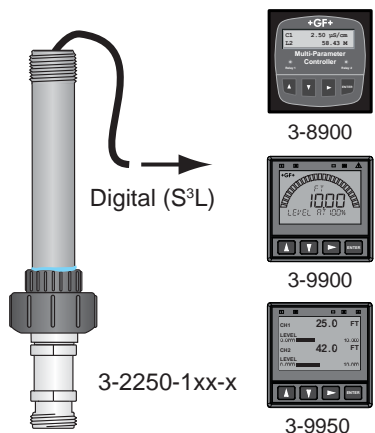

2250 with 4 to 20 mA or Digital (S³L) Output: Remote Mounting

The 2250 can provide a digital (S³L) signal to a 8900 Multi-Parameter Controller, 9900 Transmitter or 9950 Dual Channel Transmitter.

The 2250 can provide a 4 to 20 mA signal to a PLC or to a chart recorder.

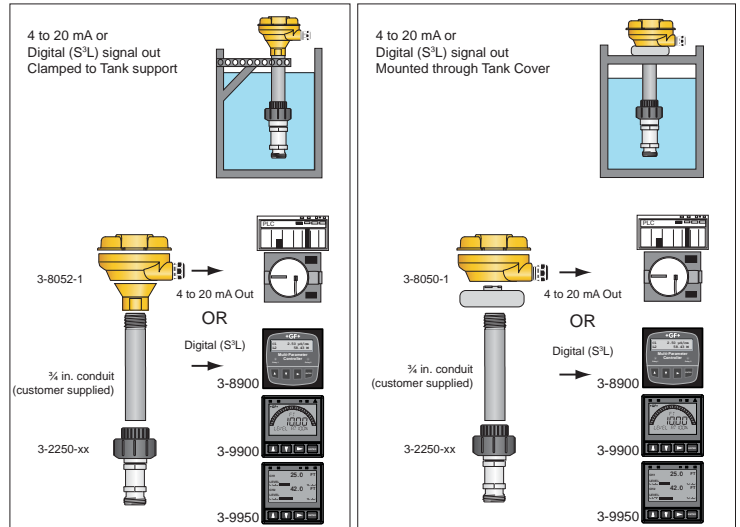

2250 with Digital Output: Integral mounting

The 2250 can be assembled as an integral system, with the 3-9900-1 Transmitter mounted directly atop the sensor. This configuration provides a local display at the measurement site, plus the 4 to 20 mA and open-collector output features of the 9900 Transmitter.

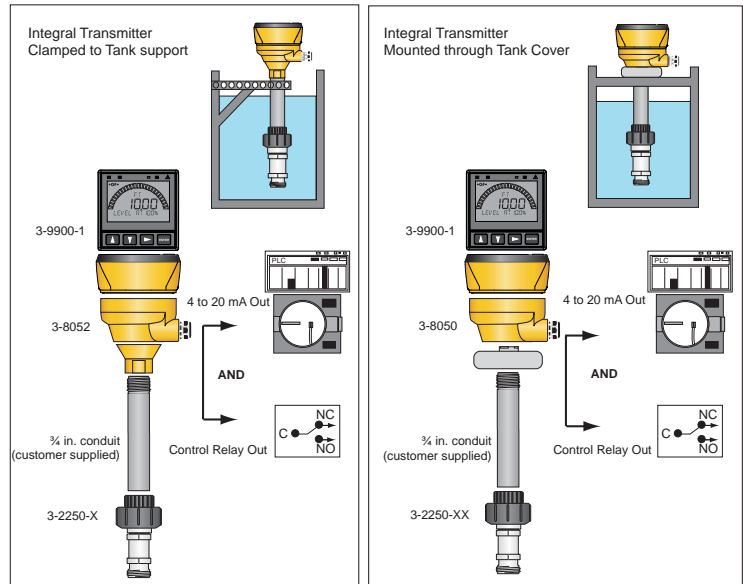

2250 Assembly Detail

1.

Glue the union bushing onto the conduit.

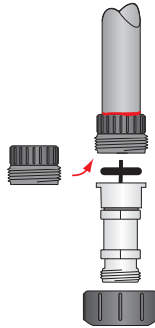

2.

Thread the sensor cable through the O-ring, Union and through the 3/4 in. conduit.



3.

Thread the Union nut onto the Union bushing.

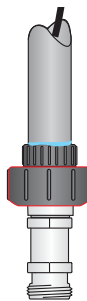

CAUTION
Hand tighten the nut. Do not use tools.

4.

Thread the 3/4 in. conduit adapter or the universal adapter onto the top of the conduit. Use a suitable thread sealant to provide a watertight connection.

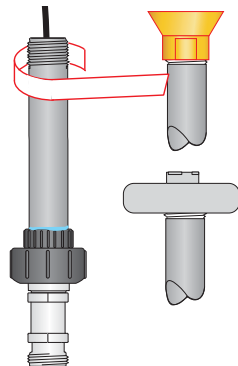

5.

Mount the conduit base onto the adapter and secure the assembly with the locking ring.



6A.

Remote system
Cut the cable to length and terminate the wires at the terminal block inside the conduit base.



CAUTION
The capillary tube that runs the length of the sensor cable must remain open to the atmosphere. Do not allow it to be crimped or blocked.

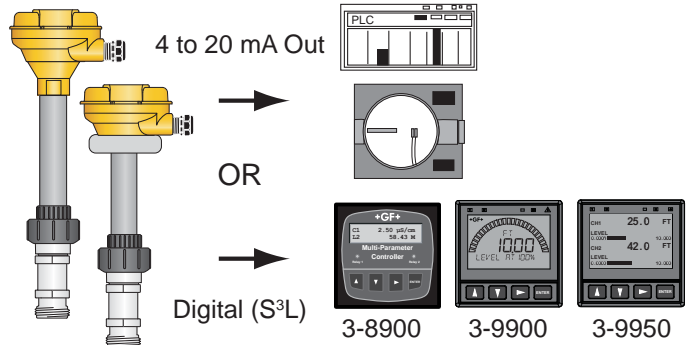
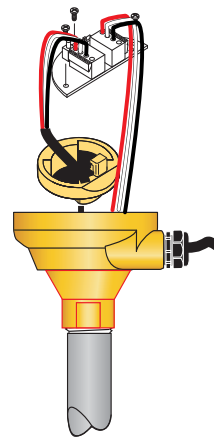

6B.

Integral system
Cut the cable to length and terminate the wires at the terminal block of a field-mounted 9900-1 Transmitter.



CAUTION
The capillary tube that runs the length of the sensor cable must remain open to the atmosphere. Do not allow it to be crimped or blocked.

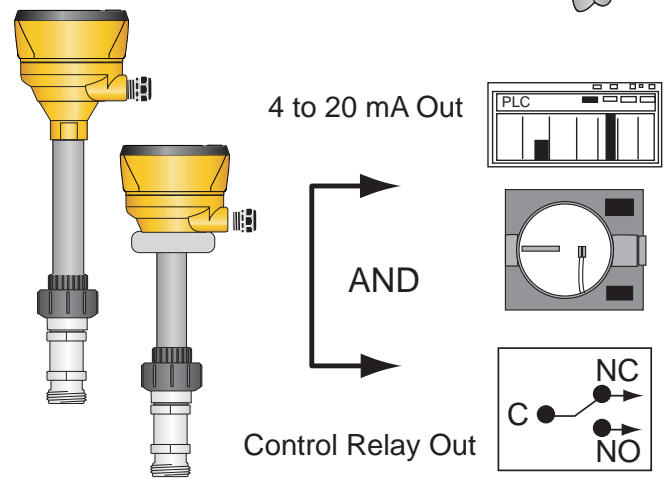
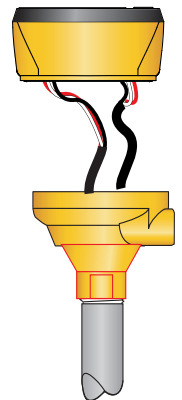

Wiring

Digital (S³L) wiring

- 3-2250-11X-X options provide Digital (S³L) output when powered with 5 VDC from a 9900 Transmitter, a 9950 Dual Channel Transmitter or a 8900 Multi-Parameter Controller.
- Connecting the SHIELD to a direct Earth ground may reduce electrical noise interference.
- The maximum Digital (S³L) cable length is dependent upon the instrument to which the sensor is connected. Consult the instrument manual for details.

3-2250-11X-X to 8900 Multi-Parameter Controller

Digital (S ³ L) Sensors
3-2250-11U
3-2250-11L
3-2250-11U-1
3-2250-11L-1

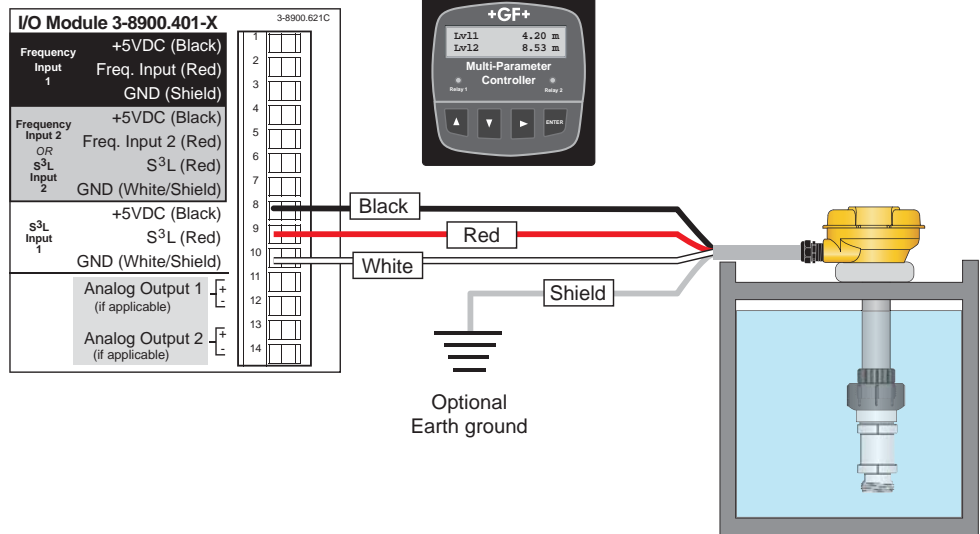

3-2250-11X-X to 9900 Transmitter

Digital (S ³ L) Sensors
3-2250-11U
3-2250-11L
3-2250-11U-1
3-2250-11L-1

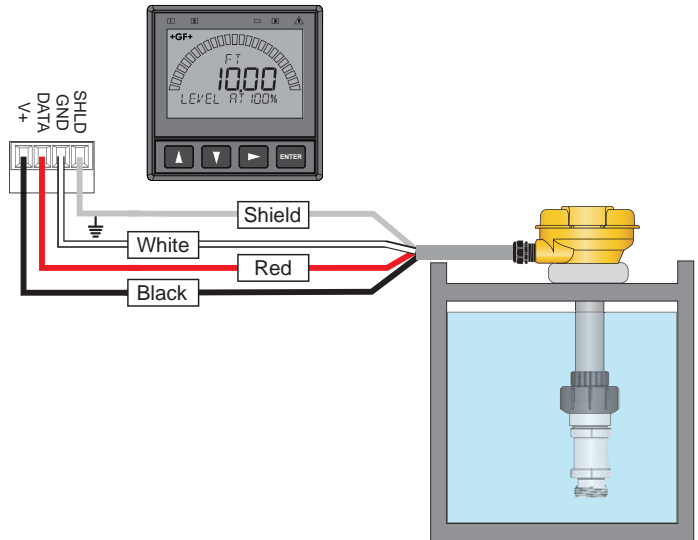

3-2250-11X-X to 9950 Dual channel Transmitter

Digital (S ³ L) Sensors
3-2250-11U
3-2250-11L
3-2250-11U-1
3-2250-11L-1

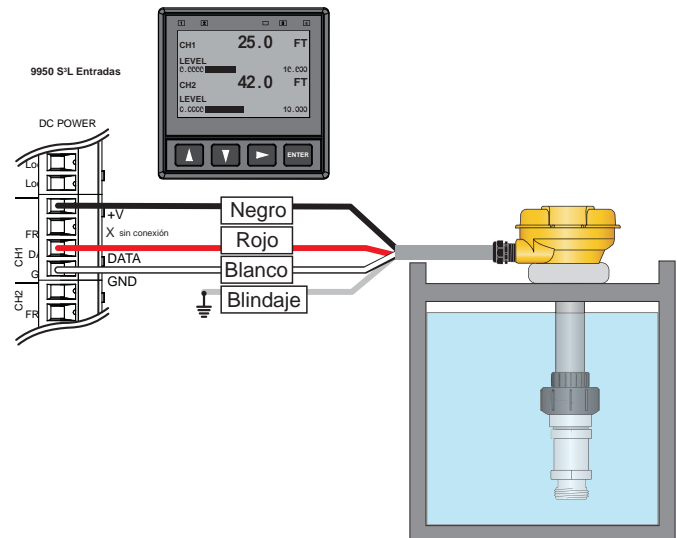

Wiring

4 to 20 mA Loop Wiring

- The 3-2250-21X-X models provide a 4 to 20 mA loop output when powered with 12 to 24 VDC.
- Connecting the SHIELD to a direct Earth ground may reduce electrical noise interference.

4 to 20 mA Sensors
3-2250-21U
3-2250-21L
3-2250-21U-1
3-2250-21L-1

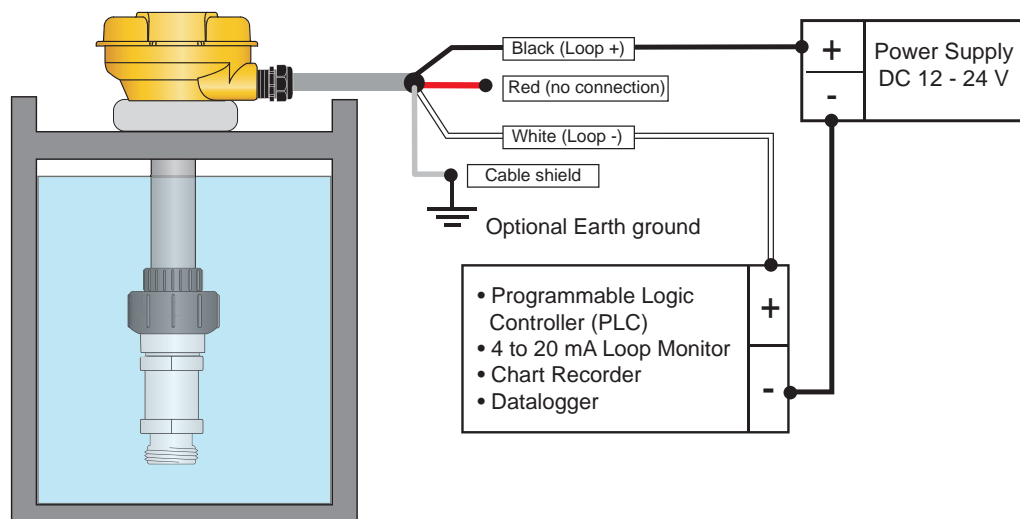

4 to 20 mA Span

The 2250 is available in two factory-set span ranges:

- Models numbers ending with "U" or "U-1" have a factory span of 0 to 10 psig.
- Model numbers ending in "L" or "L-1" are spanned for 0 to 50 psig.

The chart below lists the factory span of all available models.

The level ranges in meters and feet are based on the mass of water.

Mfr. Part No.	Code	4 to 20 mA Span
3-2250-21U	159 001 248	0 to 0.7 bar (0 to 10 psig) 0 m to 7 m (0 ft to 23.09 ft)
3-2250-21L	159 001 247	0 to 3.4 bar (0 to 50 psig) 0 m to 34 m (0 ft to 115.5 ft)
3-2250-21U-1	159 001 482	0 to 0.7 bar (0 to 10 psig) 0 m to 7 m (0 ft to 23.09 ft)
3-2250-21L-1	159 001 483	0 to 3.4 bar (0 to 50 psig) 0 m to 34 m (0 ft to 115.5 ft)

Respanning the 4 to 20 mA Output

- The 4 to 20 mA span can be set to accommodate any application within the operating range of the sensor.
- The respawning procedure requires that the sensor be subjected to the actual pressure that will represent 4 mA and 20 mA.
- The procedure illustrated here assumes that the application requires that the sensor output is 4 mA when the tank is empty and 20 mA when the tank is full. To reverse the range, reverse steps 3 and 5.



WARNING!

Not protecting the red wire may cause the 4 to 20 mA span to be reset.

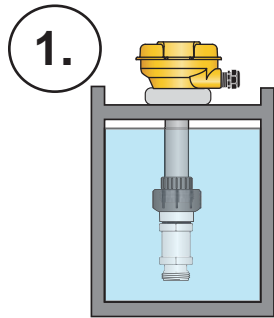
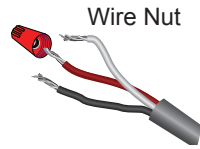

1.

Install the sensor.

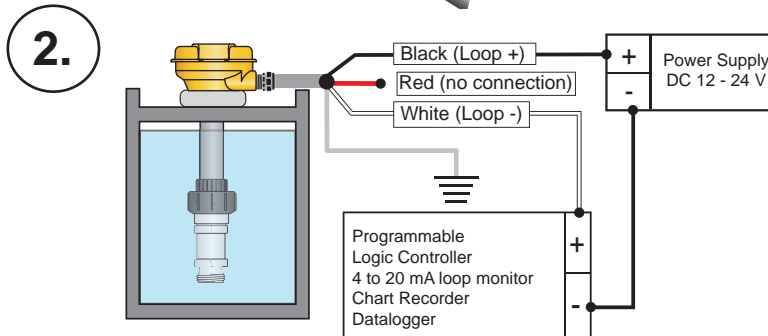

2.

Wire the 4-20 mA Loop and turn the power ON.

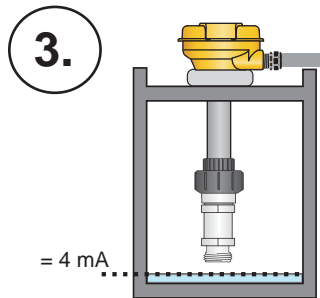

3.

= 4 mA

Fill tank to the level represented by 4 mA.

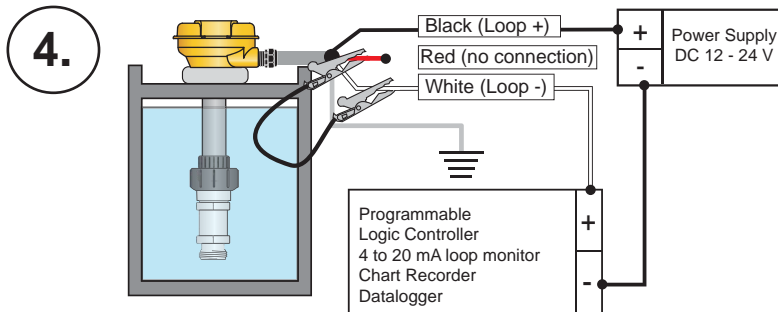

4.

Carefully remove the heat shrink tube that is protecting the red wire.
Short the RED and WHITE wires together for 15 seconds. mA should go to 3 to 6 mA
Disconnect red wire

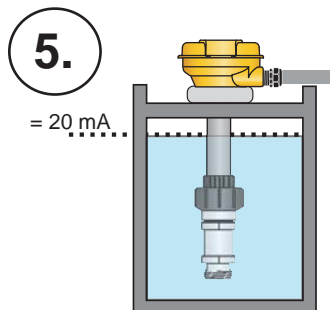

5.

= 20 mA

Fill the tank to the level to be represented by 20 mA.

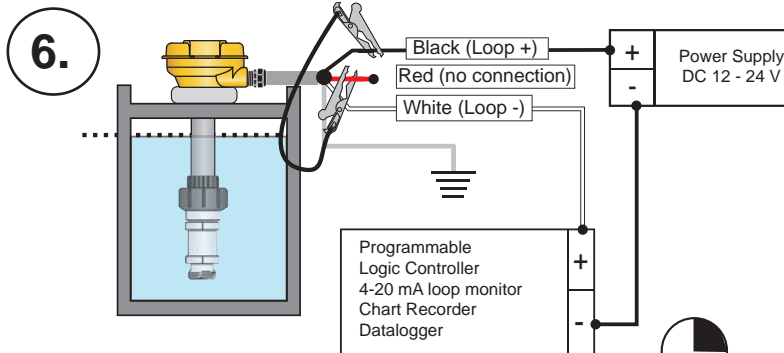

6.

Short the RED and BLACK wires together for 15 seconds.
mA should go to 22 mA
Disconnect red wire



After adjusting the 4 to 20 mA span, protect the red wire by installing the provided wire nut.

For easier re-spanning use the Signet 0252 Diagnostic Tool.

Ordering Information

2250 Hydrostatic Level Sensor

Mfr. Part No.	Code	Description
3-2250-11U	159 001 242	0 to 0.7 bar (0 to 10 psi), Digital (S ³ L), ½ in. union, ¾ in. PVC-U Union
3-2250-11L	159 001 241	0 to 3.4 bar (0 to 50 psi), Digital (S ³ L), ½ in. union, ¾ in. PVC-U Union
3-2250-21U	159 001 248	0 to 0.7 bar (0 to 10 psi), 4 to 20 mA, ½ in. union, ¾ in. PVC-U Union
3-2250-21L	159 001 247	0 to 3.4 bar (0 to 50 psi), 4 to 20 mA, ½ in. union, ¾ in. PVC-U Union
3-2250-11U-1	159 001 478	0 to 0.7 bar (0 to 10 psi), Digital (S ³ L), ½ in. union, Metric PVC-U Union
3-2250-11L-1	159 001 479	0 to 3.4 bar (0 to 50 psi), Digital (S ³ L), ½ in. union, Metric PVC-U Union
3-2250-21U-1	159 001 482	0 to 0.7 bar (0 to 10 psi), 4 to 20 mA, ½ in. union, Metric PVC-U Union
3-2250-21L-1	159 001 483	0 to 3.4 bar (0 to 50 psi), 4 to 20 mA, ½ in. union, Metric PVC-U Union

Accessories and Replacement Parts

Mfr. Part No.	Code	Description
5523-0322	159 000 761	Sensor cable (per ft.). 3 conductor plus shield, 22 AWG (black/red/white/shield)
3-9000.392-1	159 000 839	Liquid tight connector kit, NPT (1 pc.)
3-9000.392-2	159 000 841	Liquid tight connector kit, PG 13.5 (1 pc.)
3-8050	159 000 184	Universal mount kit
3-8052	159 000 188	¾ in. Integral mount kit
3-8050-1	159 000 753	Universal Mount w/Junction terminals
3-8052-1	159 000 755	¾ in. Integral mount w/Junction terminals
3-0252	159 001 808	0252 ConfigurationTool



Georg Fischer Signet LLC, 3401 Aero Jet Avenue, El Monte, CA 91731-2882 U.S.A. • Tel. (626) 571-2770 • Fax (626) 573-2057
For Worldwide Sales and Service, visit our website: www.gfsignet.com • Or call (in the U.S.): (800) 854-4090
For the most up-to-date information, please refer to our website at www.gfsignet.com