

Specification

DESIGN

Center body consists of 1 part to be mounted between two flanges according to EN 1092-1 type 11 form B - PN10 (former DIN 2501). ANSI 150 on request.

MEDIA

Liquid and pulverised media with fibre particles, viscous media, drain water, sludge, food etc. (plastic granulates, sand or similar media on request). Not suitable for steam.

BODY

- GG-25 (grey cast iron), epoxy coated (heat-treatment 190°C, 20min)
- stainless steel 1.4408.

SEALING

- Metal/metal
 - NBR
 - EPDM
- (FKM or PTFE on request)

GLAND

- 3-piece sealing set:
- 2x synthetic fibre, PTFE-coated
 - 1x NBR-, EPDM or FKM-ring

KNIFE

Stainless steel 1.4301 or 1.4401 (304 or 316)

STEM

Stainless steel 1.4305 or 1.4404 (304 or 316)

FUNCTION

Pneumatic double acting

PRESSURE DISCHARGE

One-sided, two-sided on request

PILOT PRESSURE

6bar (lower pressure on request)

PILOT MEDIA

Filtered, slightly oiled air (subject to reamaining oil, dust and water). According at least to ISO 8571, ISO 8573 or PNEUROP 6,661.

PRESSURE RANGE

Please refer to the table

TEMPERATURE RANGE

- metal: on request
- NBR: -25°C ... +90°C
- EPDM: -35°C ... +120°C

Attention: Temperature range not for all media.

FACE TO FACE

EN 558-1 Row 20

The above information is intended for guidance only and the company reserves the right to change any data herein without prior notice!

Technische Daten

AUSFÜHRUNG

1-teiliges Zentriergehäuse zum Einklemmen zwischen Flansche nach EN 1092-1 Typ 11 Form B - PN10 (früher DIN 2501). ANSI 150 auf Anfrage.

DURCHFLUSSMEDIUM

Flüssigkeiten und pulverförmige Medien mit Faseranteilen, zähflüssige Medien, Abwasser, Klärschlamm, Lebensmittel usw. (Kunststoffgranulate, Sand oder ähnliche Materialien auf Anfrage). Nicht geeignet für Dampf.

GEHÄUSE

- GG-25, epoxidbeschichtet (eingebraunt 190°C, 20min)
- Edelstahl 1.4408

DICHTUNG

- metallisch
 - NBR
 - EPDM
- (FKM oder PTFE auf Anfrage)

STOPFBUCHSPACKUNG

- 3-teiliger Dichtungssatz:
- 2x Synthetikfaser, PTFE-beschichtet
 - 1x NBR-, EPDM oder FKM-Ring

SCHIEBERBLATT

Edelstahl 1.4301 bzw. 1.4401

SPINDEL

Edelstahl 1.4305 oder 1.4404

FUNKTION

Pneumatisch doppelwirkend

DRUCKBEAUFSCHLAGUNG

einseitig, beidseitig auf Anfrage

STEUERDRUCK

6bar (niedriger Druck auf Anfrage)

STEUERLUFT

Gefilterte, leicht geölte Luft (hinsichtlich Rest-Staub und Rest-Wasser). Mindestens nach ISO 8571, ISO 8573 oder PNEUROP 6,661.

BETRIEBSDRUCK

siehe Tabelle

MEDIUMTEMPERATUR

- metallisch: auf Anfrage
- NBR: -25°C ... +90°C
- EPDM: -35°C ... +120°C

Beachten: Die Temperaturen gelten nicht für alle Medien.

BAULÄNGE

EN 558-1 Reihe 20

Alle Angaben sind freibleibend und unverbindlich!

Type:

WGE-xx-PD

Knife-Gate-Valve
pneumatic double acting

DN50 ... DN400

GG-25, Stainless steel



Artikel:

WGE-xx-PD

Stoffschieber
pneumatisch doppelwirkend

DN50 ... DN400

GG-25, Edelstahl

Features [Vorteile]

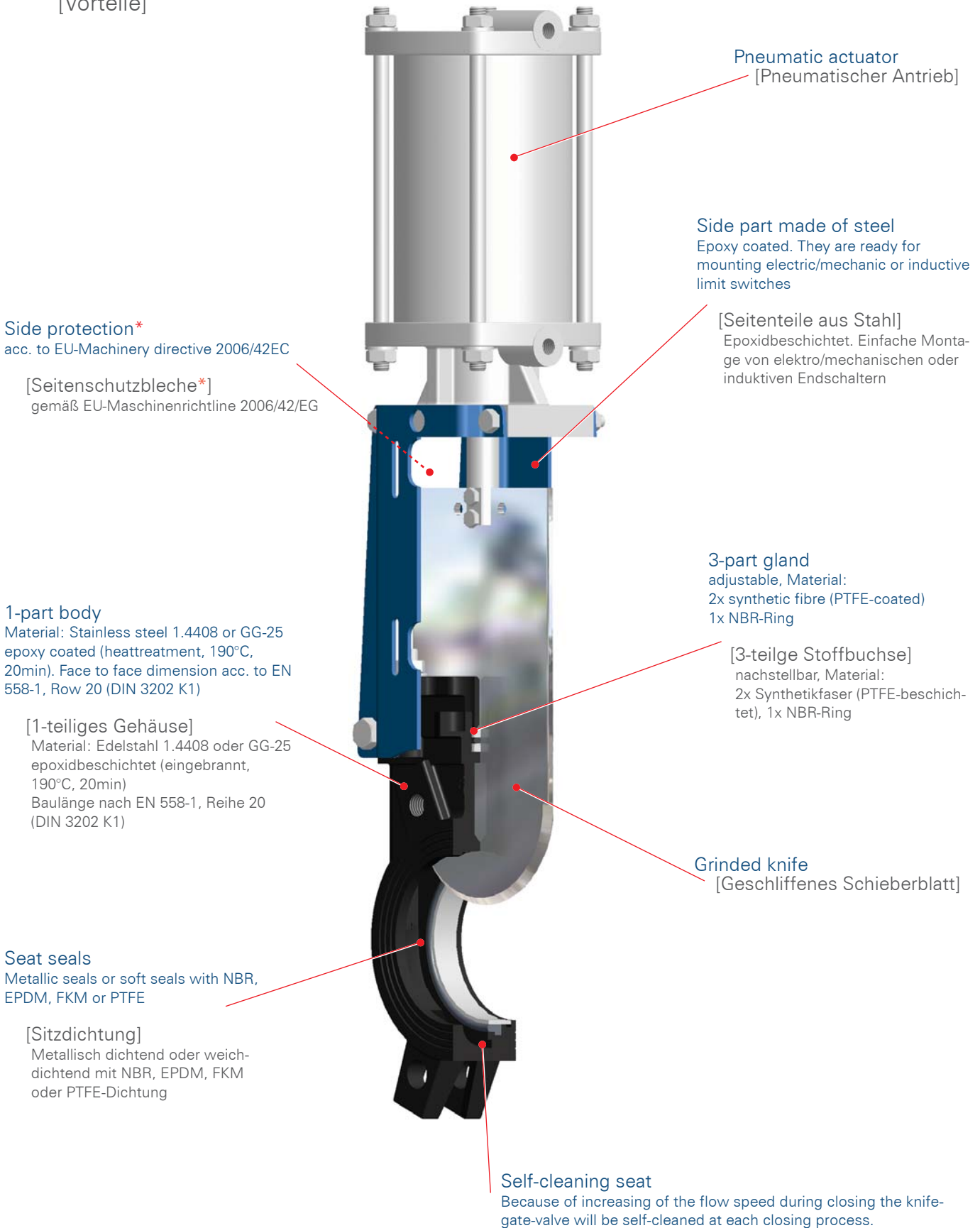

* Extracharge. Without side protection only if you mention in your order, e.g.: "Installation of the valve in inaccessible facility."

[Mehrpreis. Ohne Seitenschutzbleche nur bei schriftlichem Vermerk in der Bestellung, z.B.: "Installation des Schiebers in unzugänglichen Anlagenteilen."]

Article number key [Artikelnummernschlüssel]

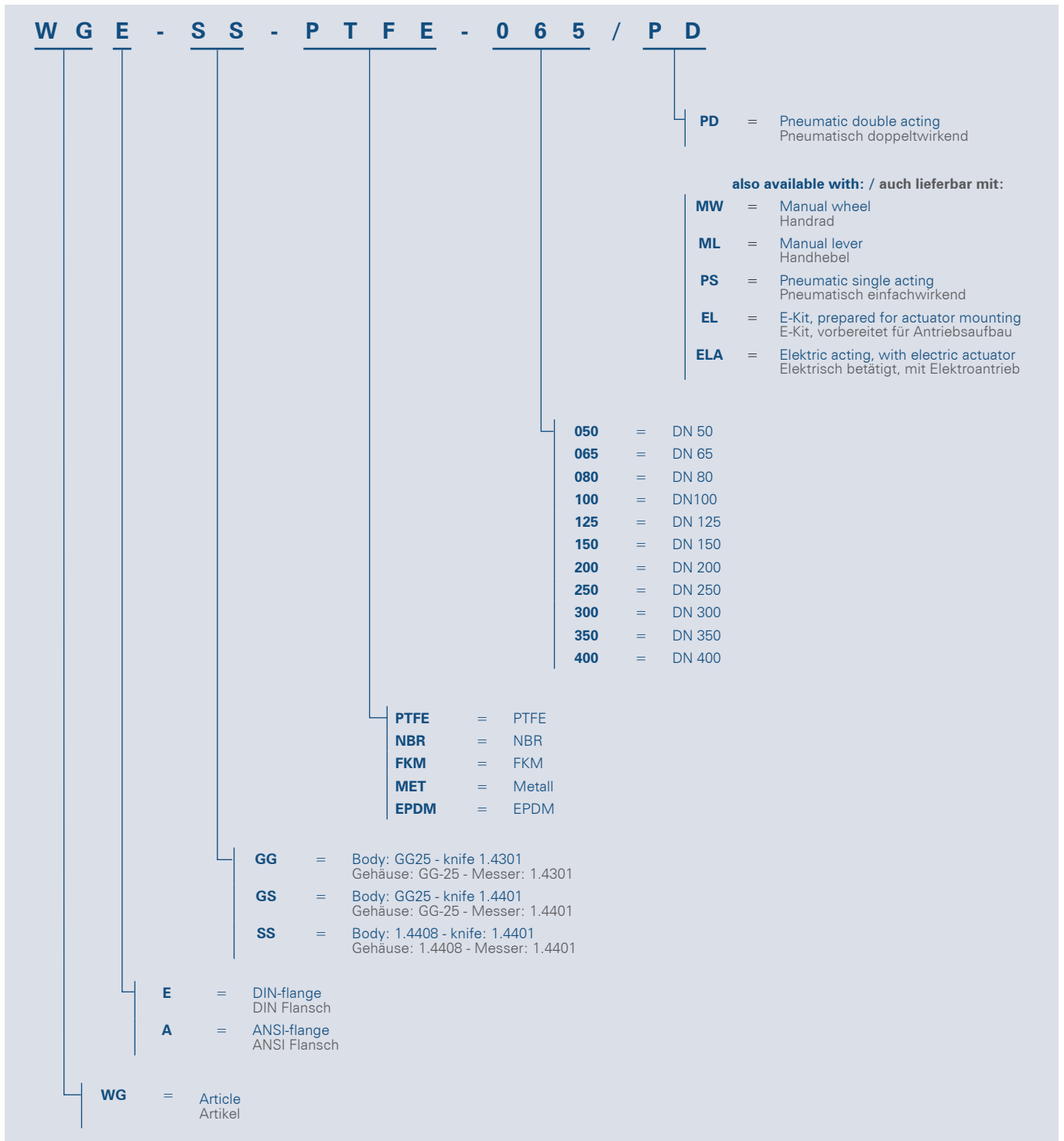

Leaking rate [Leckrate]

Please note that you have to calculate for all metallic sealing knife-gate-valves with a leaking rate of appr. 0,4% of the Kv-value (for liquid media).

Bitte beachten Sie, das bei metallisch dichtenden Stoffschiebern mit einer Leckrate von 0,4% vom Kv-Wert zu rechnen ist (dünnflüssige Medien).

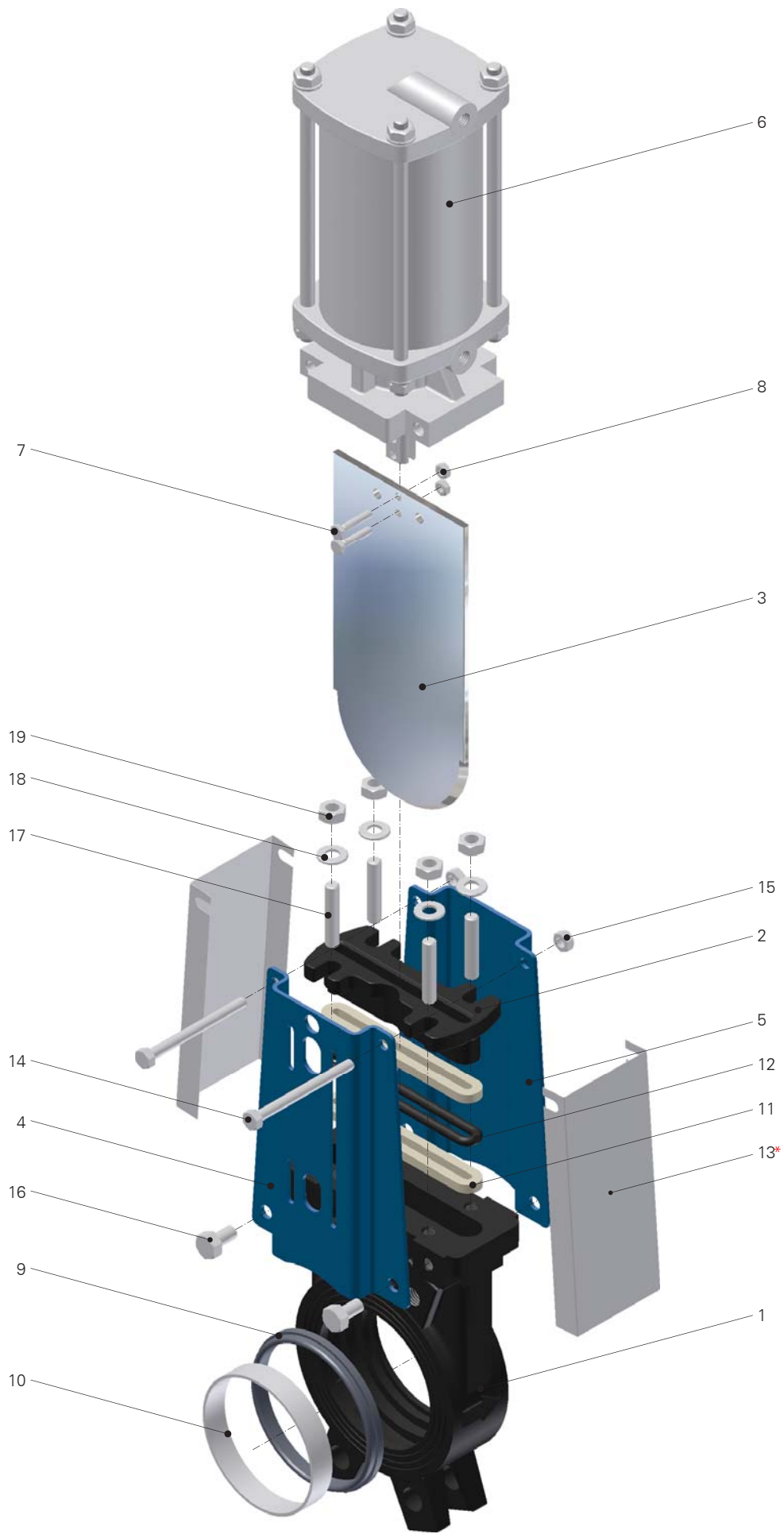

Parts list | grey cast iron
[Stückliste | GG-25]

Pos.	Description	Material	[Bezeichnung]	[Material]
1	Body	Grey cast iron	Gehäuse	Grauguß GG-25
2	Gland	Grey cast iron	Stopfbuchsbrille	Grauguß GG-25
3	Knife	Stainless steel 1.4301	Schieberblatt	Edelstahl 1.4301
4	Side part	Steel, epoxy coated	Seitenteil	Stahl, epoxidbeschichtet
5	Side part	Steel, epoxy coated	Seitenteil	Stahl, epoxidbeschichtet
6	Pneumatically actuator	Aluminium, stainless steel, steel (galvanised), NBR	Pneumatischer Antrieb	Aluminium, Edelstahl, Stahl (verzinkt) NBR
7	Screw	Steel, galvanised	Schraube	Stahl, verzinkt
8	Hexagon nut	Steel, galvanised	Sechskantmutter	Stahl, verzinkt
9	Sealing	NBR / EPDM / FKM / PTFE	Dichtung	NBR / EPDM / FKM / PTFE
10	Seat ring	Stainless steel	Sitzring	Edelstahl
11	Gland	Synthetic fibre, PTFE-coated	Stopfbuchspackung	Synthetikfaser, PTFE-beschichtet
12	Gland	NBR- / EPDM- / FKM-ring	Stopfbuchspackung	NBR- / EPDM- / FKM-Ring
13	Side protection*	Stainless steel 1.4301	Seitenschutzblech*	Edelstahl 1.4301
14	Screw	Steel, galvanised	Schraube	Stahl, verzinkt
15	Hexagon nut	Steel, galvanised	Sechskantmutter	Stahl, verzinkt
16	Screw	Steel, galvanised	Schraube	Stahl, verzinkt
17	Threaded pin	Steel, galvanised	Gewindestift	Stahl, verzinkt
18	Disc	Steel, galvanised	Scheibe	Stahl, verzinkt
19	Hexagon nut	Steel, galvanised	Sechskantmutter	Stahl, verzinkt

Parts list | stainless steel
[Stückliste | Edelstahl]

Pos.	Description	Material	[Bezeichnung]	[Material]
1	Body	Stainless steel 1.4408	Gehäuse	Edelstahl 1.4408
2	Gland	Stainless steel 1.4408	Stopfbuchsbrille	Edelstahl 1.4408
3	Knife	Stainless steel 1.4401	Schieberblatt	Edelstahl 1.4401
4	Side part	Steel, epoxy coated	Seitenteil	Stahl, epoxidbeschichtet
5	Side part	Steel, epoxy coated	Seitenteil	Stahl, epoxidbeschichtet
6	Pneumatically actuator	Aluminium, stainless steel, steel (galvanised), NBR	Pneumatischer Antrieb	Aluminium, Edelstahl, Stahl (verzinkt) NBR
7	Screw	Stainless steel	Schraube	Edelstahl
8	Hexagon nut	Stainless steel	Sechskantmutter	Edelstahl
9	Sealing	NBR / EPDM / FKM / PTFE	Dichtung	NBR / EPDM / FKM / PTFE
10	Seat ring	Stainless steel	Sitzring	Edelstahl
11	Gland	Synthetic fibre, PTFE-coated	Stopfbuchspackung	Synthetikfaser, PTFE-beschichtet
12	Gland	NBR- / EPDM- / FKM-ring	Stopfbuchspackung	NBR- / EPDM- / FKM-Ring
13	Side protection*	Stainless steel 1.4301	Seitenschutzblech*	Edelstahl 1.4301
14	Screw	Steel, galvanised (stainless steel on req.)	Schraube	Stahl, verzinkt (Edelstahl auf Anfrage)
15	Hexagon nut	Steel, galvanised (stainless steel on req.)	Sechskantmutter	Stahl, verzinkt (Edelstahl auf Anfrage)
16	Screw	Steel, galvanised (stainless steel on req.)	Schraube	Stahl, verzinkt (Edelstahl auf Anfrage)
17	Threaded pin	Stainless steel	Gewindestift	Edelstahl
18	Disc	Stainless steel	Scheibe	Edelstahl
19	Hexagon nut	Stainless steel	Sechskantmutter	Edelstahl

* Extracharge. Without side protection only if you mention in your order, e.g.: "Installation of the valve in inaccessible facility."

[Mehrpreis. Ohne Seitenschutzbleche nur bei schriftlichem Vermerk in der Bestellung, z.B.: "Installation des Schiebers in unzugänglichen Anlagenteilen."]

Dimensions
[Abmessungen]

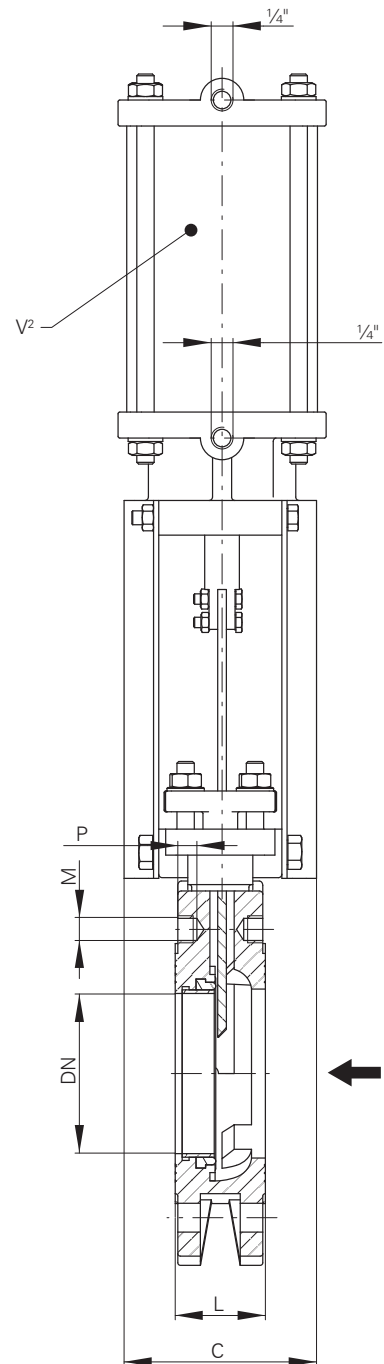
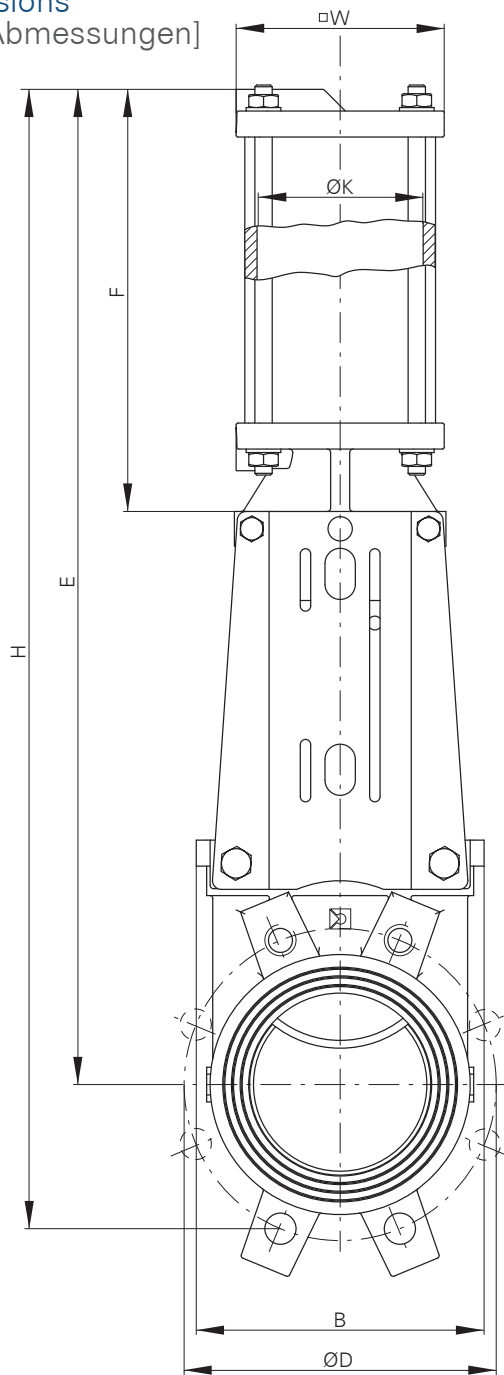

DN	$\varnothing D$	$\varnothing K^1$	H	L	E	F	B	C	$\square W$	n	M	P	V^2	J	bar	kg
50	125	80	491	43	446	195	116	102	103	4	M16	8	573	$\frac{1}{4}$	10	9
65	145	80	543	46	491	205	131	102	103	4	M16	9	625	$\frac{1}{4}$	10	10
80	160	80	591	46	519	220	146	102	103	8	M16	9	692	$\frac{1}{4}$	10	11
100	180	100	664	52	575	245	166	112	120	8	M16	9	1.260	$\frac{1}{4}$	10	14
125	210	125	738	56	640	280	197	112	150	8	M16	9	2.342	$\frac{1}{4}$	10	19
150	240	125	829	56	714	300	222	112	150	8	M20	10	2.610	$\frac{1}{4}$	10	22
200	295	160	1.025	60	885	365	275	130	185	8	M20	10	5.231	$\frac{1}{4}$	8	38
250	350	200	1.230	68	1.056	438	332	130	228	12	M20	12	10.053	$\frac{1}{4}$	7	57
300	400	200	1.413	78	1.216	488	386	130	228	12	M20	14	11.574	$\frac{1}{4}$	6	75
350	460	250	1.590	96	1.360	515,5	437	196	278	16	M20	20	19.145	$\frac{3}{8}$	6	127
400	515	250	1.770	100	1.512	565,5	491	196	278	16	M24	23,5	21.600	$\frac{3}{8}$	5	138

1) Piston diameter
[Kolbendurchmesser]

2) Volume of the pneumatic actuator cm^3
[Volumen des pneumatischen Antriebs in cm^3]

Flange and boring detail | DIN PN10 [Flansch- und Bohrungsdetail | DIN PN10]

DN	ØK	n	M	T	●	⊕
50	125	4	M16	8	2	2
65	145	4	M16	9	2	2
80	160	8	M16	9	2	2
100	180	8	M16	9	2	2
125	210	8	M16	9	2	2
150	240	8	M20	10	2	2
200	295	8	M20	10	2	2
250	350	12	M20	12	4	2
300	400	12	M20	14	4	2
350	460	16	M20	20	6	6
400	515	16	M24	23,5	6	6

● Threaded blind hole
[Sackbohrung, Gewinde]

⊕ Through hole
[Durchgangsbohrung]

DN50 - DN65

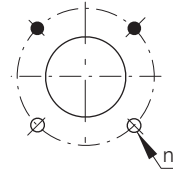

DN80 - DN200

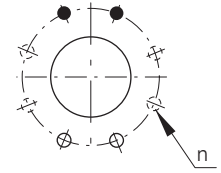

DN250 - DN300

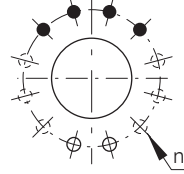

DN350 - DN400

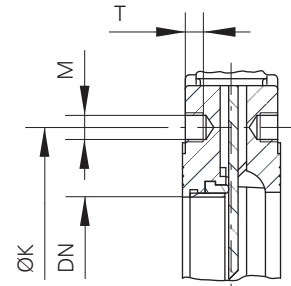
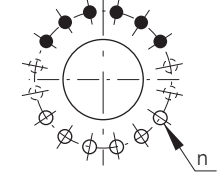

Flange and boring detail | ANSI B16.5, class 150 [Flansch- und Bohrungsdetail | ANSI B16.5, class 150]

Only on request!

3" and 14" applied to ANSI B16.5, class 150 (different numbers of holes)

Nur auf Anfrage!

3" und 14" angelehnt an ANSI B16.5, class 150 (abweichende Bohrungsanzahl)

DN	ØK	n	M	T	●	⊕
2"	4¾"	4	5/8" UNC	8	2	2
2½"	5½"	4	5/8" UNC	9	2	2
3"	6"	8*	5/8" UNC	9	2	2
4"	7½"	8	5/8" UNC	9	2	2
5"	8½"	8	¾" UNC	9	2	2
6"	9½"	8	¾" UNC	10	2	2
8"	11¾"	8	¾" UNC	10	2	2
10"	14¼"	12	7/8" UNC	12	4	2
12"	17"	12	7/8" UNC	14	4	2
14"	18¾"	16*	1" UNC	20	4	2
16"	21¼"	16	1" UNC	23,5	6	6

* Knife-gate valves 3" will be delivered in 8-hole flange execution and valves 14" in 16-hole flange execution!

* [Stoffschieber 3" werden in 8-Loch Flanschausführung, Stoffschieber in 14" in 16-Loch Flanschausführung geliefert!]

● Threaded blind hole
[Sackbohrung, Gewinde]

⊕ Through hole
[Durchgangsbohrung]

DN2" - DN2½"

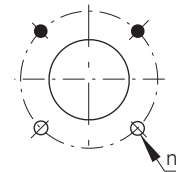

DN3" - DN8"

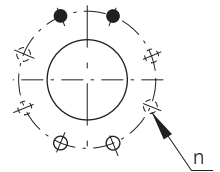

DN10" - DN14"

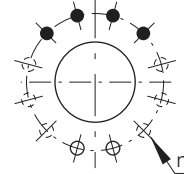

DN16"

