

Technische Daten

BAUFORM

2-teilige Körperkonstruktion (verschraubt).

BETÄTIGUNG

Drehung des Handrades.

ANSCHLUß

Innengewinde 1/2 bis 2 nach DIN 2999

BETRIEBSDRUCK

Großvakuum bis Nenndruck PN 16 bis +80°C.
Bei Betriebstemperaturen über +80°C siehe Druck-Temperatur-Diagramm.

TEMPERATUR

-20°C bis max. +180°C.

WERKSTOFFE

Gehäuse: Edelstahl 1.4408
Deckel: Edelstahl 1.4408
met. Innenteile: Edelstahl
Spindeldichtung: PTFE
Sitzdichtung: PTFE

Alle Angaben sind freibleibend und unverbindlich.

Specification

DESIGN

Body consists of 2 screwed parts.

OPERATION

Rotation of the handwheel.

CONNECTION

Female B.S.P. thread 1/2 - 2 according to DIN 2999

PRESSURE RANGE

Almost vacuum up to nominal pressure PN 16 up to +80°C. For higher temperatures please refer to the Pressure-Temperature-Diagram.

TEMPERATURE RANGE

-20°C up to +180°C.

MATERIALS

Body: Stainless steel AISI 316
Cap: Stainless steel AISI 316
met. internal parts: Stainless steel
Stem seal: PTFE
Seat: PTFE

The above information is intended for guidance only and the company reserves the right to change any data herein without prior notice!

Druck-Temperatur-Diagramm / Pressure-Temperature-Diagram

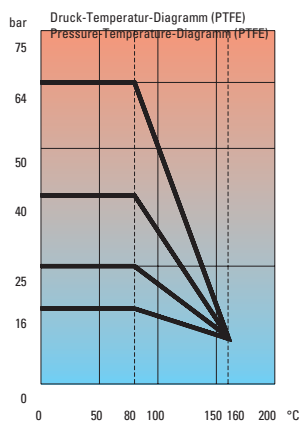

Artikel:
EBAD

Schrägsitzventil
PN 16

Edelstahl



Type:
EBAD

Angle seat valve
PN 16

Stainless steel



Artikel- u. Bestellangaben: z.B. EBAD311025

= Schrägsitzventil, Edelstahl / PTFE, Innengewinde G 1

1.+ 2. Stelle Produkt	3.+ 4. Stelle Werkstoffe Gehäuse / Dichtung	5. Stelle Betätigung	6. Stelle Zusatzausstattung	7.+ 8. Stelle Anschlußgröße (nach DIN 2999)
EBAD= Schrägsitzventil	31 = Edelstahl / PTFE	1 = Handrad	0 = ohne	23 = 1/2" 24 = 3/4" 25 = 1" 26 = 1 1/4" 27 = 1 1/2" 28 = 2"

Ordering example: e.g. EBAD311025

= Angle seat valve, stainless steel / PTFE, female B.S.P. thread, G 1

1.+ 2. Digit Product	3.+ 4. Digit Material Body / Seal	5. Digit Operation	6. Digit Connection	7.+ 8. Digit Connection size (acc. to DIN 2999)
EBAD= Angle seat valve	31 = Stainless steel / PTFE	1 = Handwheel	0 = without	23 = 1/2" 24 = 3/4" 25 = 1" 26 = 1 1/4" 27 = 1 1/2" 28 = 2"

Abmessungen und Stückliste / Dimensions and Parts list

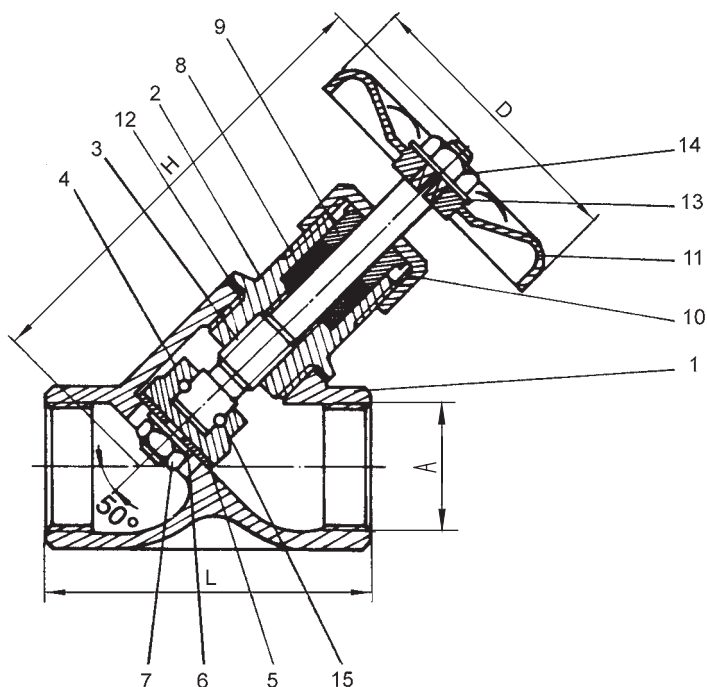

A	L	H	D
1/2	65,5	100	63
3/4	75,5	125	75
1	90,5	130	75
1 1/4	111	165	100
1 1/2	121	170	100
2	151	210	100

Pos.	Bezeichnung / Description		Material / Material	
1	Gehäuse	Body	Edelstahl 1.4408	Stainless steel AISI 316
2	Deckel	Cap	Edelstahl 1.4408	Stainless steel AISI 316
3	Spindel	Stem	Edelstahl 1.4401	Stainless steel AISI 316
4	Ventilteller	Valve disc	Edelstahl 1.4401	Stainless steel AISI 316
5	Sitzdichtung	Seat seal	PTFE	PTFE
6	Scheibe	Washer	Edelstahl 1.4301	Stainless steel AISI 304
7	Sechskantmutter	Hexagon nut	Edelstahl 1.4301	Stainless steel AISI 304
8	Spindelpackung	Stem packing	PTFE	PTFE
9	Packungsring	Gland	Edelstahl 1.4301	Stainless steel AISI 304
10	Packungsmutter	Packing nut	Edelstahl 1.4301	Stainless steel AISI 304
11	Handrad	Handwheel	Stahl	Carbon steel
12	Gehäusedichtung	Body seals	PTFE	PTFE
13	Scheibe	Washer	Edelstahl 1.4301	Stainless steel AISI 304
14	Sechskantmutter	Hexagon nut	Edelstahl 1.4301	Stainless steel AISI 304
15	Ventiltellerstift	Valve disc pin	Edelstahl 1.4404	Stainless steel AISI 316