

Pressure Reducing Valve Type 582

Compact, Easy to adjust, Flexible



Benefits

Easy Installation:

- Compact design enables installation even when space is limited
- Radially dismountable
- Integrated assembling aid enables direct assembly of the valves to mounting sets
- Significantly shorter take-out length with union connections

Easy Operation:

- No re-torquing needed anymore due to central housing nut
- Easily adjustable set pressure
- Constant and low vibrating control behavior
- Tightness resistant with temperature cycles
- Low-maintenance
- Pressure setting even during operation

Flexible:

- Manometer optional for neutral and aggressive media
- Various connection options due to the true union or spigot version.
- Low pressure spring set available
- Easy on spare parts due to modular design, one part might fit more than one valve

Market Segments

- Water Treatment
- Chemical Process Industry
- Microelectronics
- Solar industry

Function

The pressure reducing valve reduces the line pressure to a set value on the valve outlet. The outlet pressure is in no direct relation to the inlet pressure. Independent of raising or falling inlet pressure the outlet pressure stays largely constant.

Flow Media

Neutral and aggressive media with low number of particles/ solids.

Depending on selected valve material mind the chemical resistance. → Please refer to Georg Fischer Piping System Chemical Resistance List

Media Temperature

See pressure-/ temperature diagram

Pressure Rating

PN 10 @ +20°C (150 psi @ 68°F)

Set-Range

Standard: 0.5- 9.0 bar (7 – 130 psi)

Optional: 0.3 – 3 bar (4 – 44 psi)

Hysteresis

Difference between opening and closing pressure:

Approx. 0.1 – 0.4 bar (1.5 – 5.8 psi)

Dimensions

DN 10 - DN 50 (3/8" – 2")

Wetted Parts (Body, Piston, Inner-housing)

- PVC-U / CPVC (Polyvinylchlorid)
- PP (Polypropylen)
- PVDF (Polyvinylidenfluorid)
- PTFE (Polytetrafluoraethylen)

Valve Housing

PP-GF (orange)

Diaphragm

- EPDM/PTFE

Seals

- EPDM
- FPM

Connections

- Body with cementing resp. welding spigots
- Body true union type connection to match all standard GF unions and inserts (similar to diaphragm valve)

Available on request:

Various inserts from the GF range, e.g. transition to metal or PE.

Mounting

Threaded inserts available for safe mounting

Flow Direction

Always according to arrow in body

Valve Function and Design

The opened valve is in balance between the inlet pressure P1 (primary side) and the lower working pressure P2 (secondary side).

If the working pressure goes above or below the set value, the diaphragm is lifted against the spring force or pressed down by the spring force. The valve starts closing or opening until the equilibrium condition is reached again, e.g. the working pressure remains largely constant independent of an increasing or decreasing inlet pressure (as long as the inlet pressure > working pressure).

Pressure-Temperature Diagram

The following Pressure-Temperature Diagrams are based on a lifetime of 25 years with water or similar media.

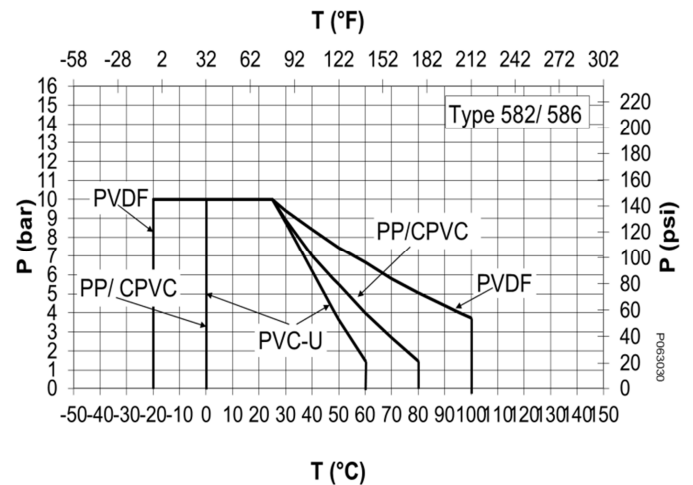

P Permissible pressure in bar, psi

T Temperature in °C, °F

Kv Values

K_{V100} @ $\Delta p = 1$ bar

C_{V100} @ $\Delta p = 1$ psi

DN [mm]	inch	d [mm]	K_{V100}		
			[L/min]	[L/h]	[gpm]
10	3/8	16	45	2'700	11.9
15	1/2	20	48	2'850	12.5
20	3/4	25	112	6'700	29.5
25	1	32	129	7'730	34.0
32	1 1/4	40	254	15'240	67.1
40	1 1/2	50	293	17'590	77.4
50	2	63	319	19'170	84.4

Standards

- Tightness according to ISO 9393
- Leak rate according to EN 12266

Sectional View Pressure Reducing Valve Type 582

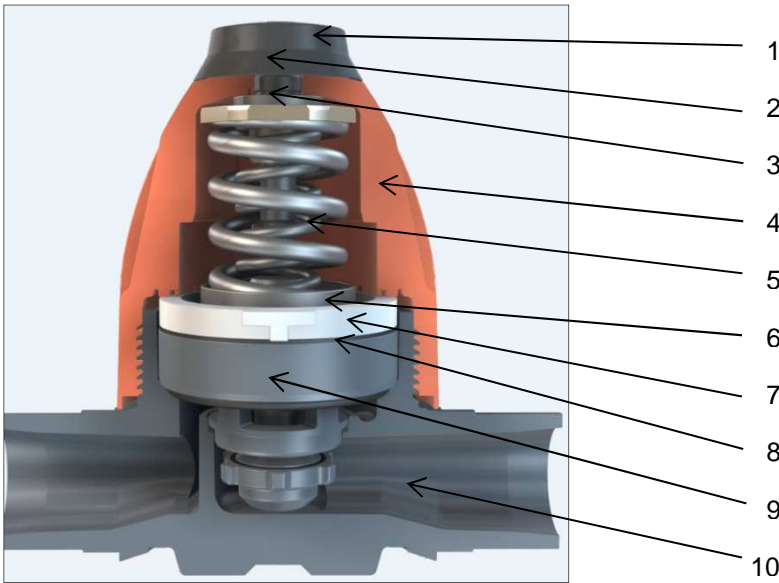

No.	Description
1	Protecting Cap
2	Lock-Nut
3	Spindle
4	Housing
5	Spring(s)
6	Spring Retainer
7	Retainer Ring
8	Diaphragm
9	Cartridge with Piston
10	Body

Dimensions Type 582 with Unions, Cementing resp. Welding Sockets

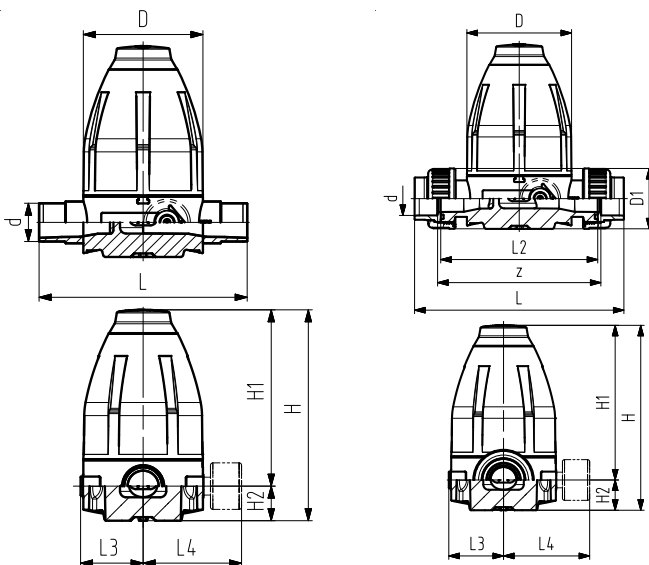

All Materials	d (mm)	DN (mm)	DN (inch)	D	H	H1	H2
	16 20	10 15	3/8 1/2	79	132	111	21
	25 32	20 25	3/4 1	100	177	148	29
	40 50	32 40	1 1/4 1 1/2	147	251	207	44
	63	50	2	147	251	207	44

All Materials if not indicated	d (mm)	DN (mm)	DN (inch)	L* PVC/ PP	L* PVDF	L2	L3	L4	z PVC/ PP	z PVDF
	16 20	10 15	3/8 1/2	134	150	120	42	77	126	130
	25 32	20 25	3/4 1	174	190	150	53	88	156	160
	40 50	32 40	1 1/4 1 1/2	224	240	205	76	111	211	215
	63	50	2	244	260	205	76	111	211	215

* L for Spigot Version only

Characteristic Curve Type 582

The curves below are valid for the set range 0.5- 9.0 bar (7 – 130 psi) and show the secondary or outlet pressure P2 over the flow Q in l/h. Parameter is the set pressure pE at Q = 0 l/h. There curves are valid for water at +20 °C for a flow velocity of 2 m/s. Special version set range 0.3 – 3 bar (4 – 44 psi) available on request.

