

STRAIGHT SELF CLOSING VALVE

DIN

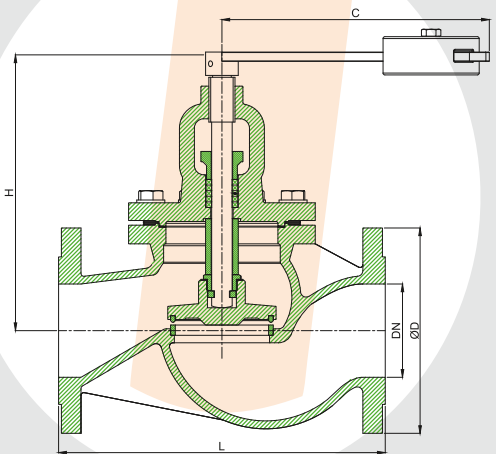
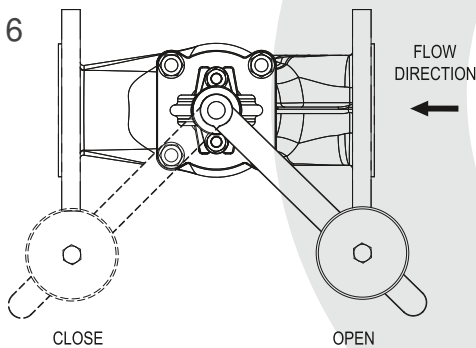

Fig 801BC

Cast Iron / SS
With Lever



- DIN 3202 F1
- Flanged PN 16



DN [mm]	ØD [mm]	L [mm]	H [mm]	C [mm]	Weight [Kg]	IMPA	Order Code
15	95	130	160	245	3	-	801BC015
20	105	150	160	245	6	-	801BC020
25	115	160	170	245	7	-	801BC025
32	140	180	170	245	8	-	801BC032
40	150	200	210	295	13	-	801BC040
50	165	230	220	295	15	-	801BC050
65	185	290	225	295	21	-	801BC065
80	200	310	270	295	28	-	801BC080
100	220	350	280	295	40	-	801BC100

*All information are indicative data. JONAS has the rights to make changes without prior notice.