

## Axiom<sup>TM</sup> AX

# Explosionproof on/off valve controller





## Axiom™ AX

# Advanced performance and reliability in harsh environments

The Axiom explosionproof platform, available in epoxy-coated anodized aluminum or stainless steel, will withstand your most challenging plant environments. Its advanced position monitoring and integral pneumatic control offer the ultimate in reliability, convenience, and value.

### Exceptional reliability

The Axiom is designed to perform reliably in adverse conditions. Its non-contact position sensing system, with fully potted and sealed electronics, is completely protected inside the water-tight explosionproof enclosure. The integral pneumatic control is tolerant of contaminants and able to operate on standard plant air. A rebreather capability is also standard, eliminating potential ingestion of outside contaminants into the spring side of single-acting actuators.

### Universal application

One conventional model will satisfy most applications with standard 20 to 240 VAC or VDC monitoring feedback and solenoid control. Standard models also feature high flow five-way, two-position pneumatic control suitable for both single- and double-acting actuation. Bus communication models offer the same pneumatic control and have pilots tuned for very low power consumption minimizing voltage drops on long cable runs.

### Space efficient design

The Axiom AX encloses all electrical components in an explosionproof compartment with less than 5" (130 mm) clearance requirement above the top of the actuator. Additional clearance for cover removal is less than 2" (50 mm) because there is no shaft to lift over. The automated valve spacing envelope is minimized without compromising performance or maintainability.

### Rugged construction

Choose from the robust epoxy-coated anodized aluminum or the 316 stainless steel enclosure designed for explosionproof applications. This platform is extremely durable and is also well-suited for use in corrosive, heavy washdown and high seas environments.

Axiom AX

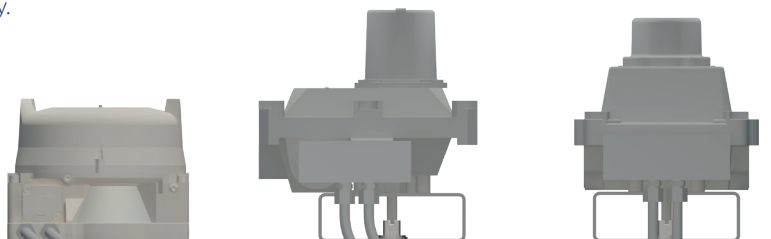

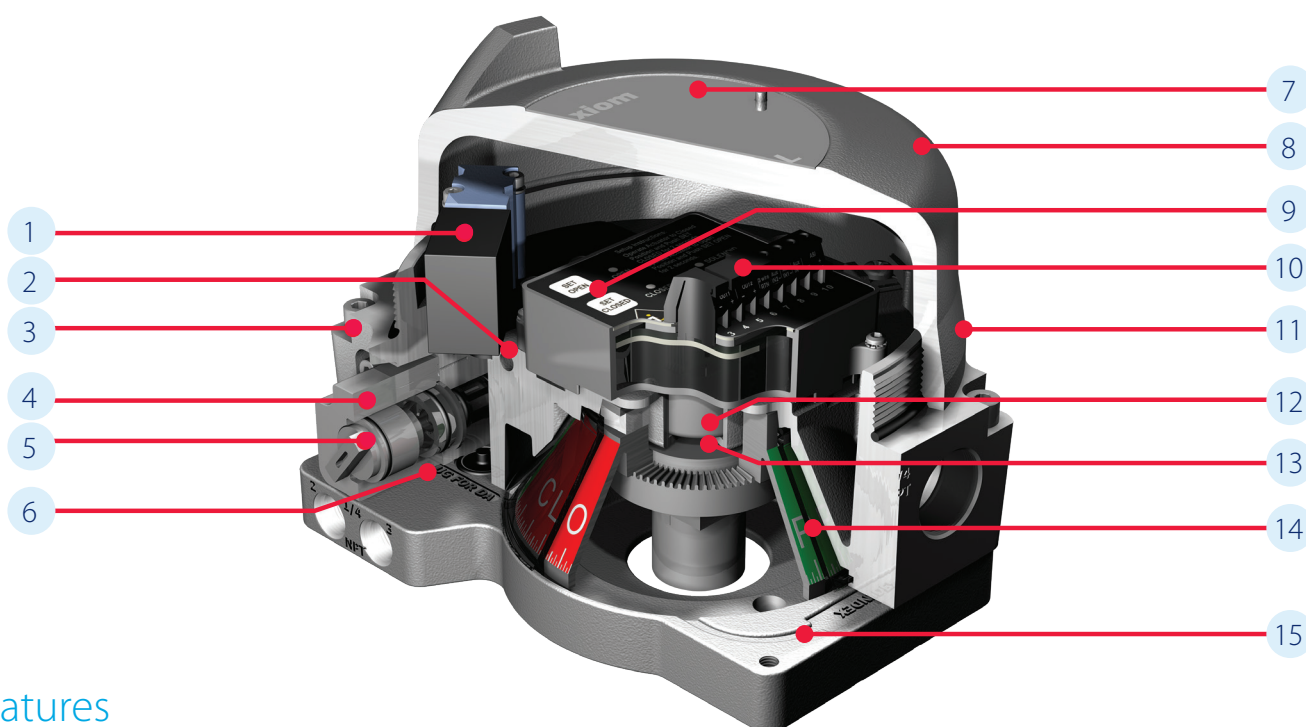

## Features

1. **Universal voltage solenoid system** operates on less than 0.6 watts of power and is burn out proof. Standard version will accept 24 VDC, 120 VAC or 240 VAC reducing stocking requirements.
2. **Prefiltered pilot valve provides** additional protection from contaminants.
3. **Easy removal from automated valve package is accomplished** with captured stainless steel fasteners and unique modular design.
4. **Integral pneumatic valve operates** on standard plant air, will cycle most actuators in less than two seconds, and is modularized for easy clean out if fouling occurs.
5. **External pneumatic valve override** options are available enabling local automated valve operation. (Internal pilot momentary override is standard on all solenoids.)
6. **Standard 5-way, 2-position valve** operates both single-acting and double-acting actuators and features a standard rebreather to feed instrument air into spring side of actuator to keep out corrosives.
7. **Highest explosionproof ratings** suitable for use in Ex d IIC Zone I and Class I, Division 1 areas.

8. **Durable enclosure and manifold/ mounting plate** are available in epoxy-coated anodized aluminum or 316 stainless steel. All fasteners, indicator couplers, and pneumatic valve end-caps are made of 316 stainless steel.
9. **Push button set points for open and closed** accurately lock in position settings which remain in place when power is removed and reapplied.
10. **Electronic components are sealed** and potted inside function module to protect against residual moisture, vibration, and corrosives.
11. **Rapid enclosure access with** the screw-on cover saves valuable maintenance and set-up time. The cover provides a vapor tight seal and allows entry to internal components in seconds.
12. **High accuracy position sensor** system is solid state with no moving wear points for highly reliable and precise position feedback.
13. **No bushings or shafts will wear out.** Electronic module, with magnetically driven position sensor, is fully isolated from the outside environment. Actuator wear causing shaft "wobble" will not affect monitoring performance.

14. **High visibility mechanical and electronic indication** confirms open/closed position and solenoid status for greater safety and convenience.
15. **Axiom directly attaches to VDI/VDE 3845 (NAMUR) actuators** and many others using a compact mounting manifold system (sold separately).



Stainless steel enclosure



Epoxy-coated aluminum enclosure

## Pneumatic control

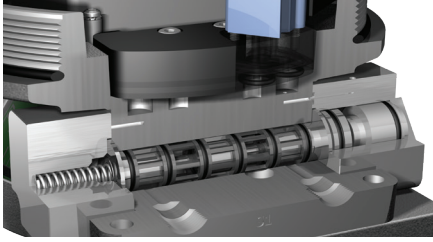

The Axiom's pneumatic valve system consists of a low-power pilot that drives the main high-flow spool valve. Pilots may be selected for conventional or bus networking applications. Both stages of the pneumatic valve system have been designed for long life, high tolerance to air line contaminants, and ease of maintenance should components become fouled.

### Special features

- Pilot and main spool design offer long life, exceptional tolerance to dirty air, and tight shut-off.
- Spool and pilot valve may be conveniently removed and cleaned if large contaminants become lodged in the valve.
- Universal voltage solenoid system may be used for standard AC or DC applications.
- Five-way, two-position spring return configuration may be used for either single- or double-acting actuators. Dual coil shuttle piston versions are also available for fail-in-last position.
- Low power consumption of solenoid reduces current flow on bus networks enabling more units and longer distances on a single segment.
- Rebreather channels exhausted air from pressurized side of actuator into spring side, preventing ingestion of contaminated air from the environment that may corrode springs or actuator internals.
- Standard internal manual override enables convenient set-up.
- Removable stainless steel sintered metal prefilter reduces potential for fouling pilot valve.
- Available in 0.7 or 1.2 Cv to satisfy pneumatic flow requirements for most actuators.

### Dual pilot configuration

Dual pilot options may be selected for special applications such as shuttle piston for fail-in-last position. External manual override options are also readily available. For special valve configurations with non-standard manual override features please consult StoneL.

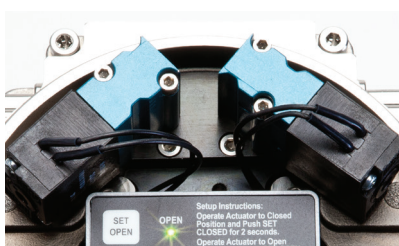

### General pneumatic valve specifications

Valve design	Pilot operated spool valve	
Pilot operator options	Solenoid coil or piezo	
Configuration	Single pilot: 5-way, 2-position spring return Dual pilot: 5-way, 2-position shuttle piston	
Flow rating	0.70 Cv or 1.2 Cv	
Axiom porting	¼" NPT (0.70 Cv); ⅜" (1.2 Cv)	
Manifold porting	¼" NPT (0.70 Cv and 1.2 Cv)	
Operating pressure	40 to 120 psi (2.7 to 7.5 bar)	
Filtration requirements	40 micron (Piezo), 30 micron	
Operating temperature	See pilot specifications below	
Manual override	Internal momentary standard External momentary available External latching available	
Aluminum enclosure	Spool: nickel-plated aluminum Body: epoxy-coated anodized aluminum Seal spacers: Polysulfone End-caps and fasteners: 316 stainless steel Spool seals: nitrile compound O-rings: nitrile compound	
Stainless steel enclosure	Spool: Teflon-coated stainless steel Body: 316 stainless steel Seal spacers: Polysulfone End-caps and fasteners: 316 stainless steel Spool seals: nitrile compound O-rings: nitrile compound	
<b>Piezo pilot (bus powered Foundation Fieldbus)</b>		
Filtration requirements	Dried/30 micron	
Operating temperature	-10° to 60° C (14° to 140° F)	
Electrical ratings	_A option 2 mA @ 6.5 VDC	
<b>Solenoid pilot</b>		
Filtration requirements	40 micron	
Electrical ratings	_H option 0.6 watt @ 22 - 250 VAC/VDC _D option 0.5 watt @ 24 VDC _E option 0.5 watt @ 12 VDC (intrinsically safe)	
Operating temperature	<b>0.7 Cv</b> <b>1.2 Cv</b> Standard (S) -18° to 50° C (0° to 122° F)    -10° to 50° C (14° to 122° F) Extended (T) -40° to 80° C (-40° to 176° F) Consult factory	

## Manifold and mounting system

The mounting manifold system directly attaches the Axiom to the actuator and ports air from the pneumatic valve to the actuator. Included in the manifold system are:

1. Actuator shaft adaptor and fastener.
2. Epoxy-coated anodized aluminum or stainless steel mounting plate manifold with o-rings and stainless steel fasteners.

The manifold system readily adapts to VDI/VDE 3845 NAMUR sizes 1 and 2. Special variations may be made for sizes 3, 4 and non-standardized quarter-turn actuator mounting patterns.

### Modular mounting design cuts valve removal costs

The Axiom enclosure may be quickly and conveniently disconnected from the actuator. Electrical components and wiring, along with pneumatic supply, may remain attached to the explosionproof enclosure while it is removed from the mounting/manifold plate (pneumatic supply should be shut off). Mounting/manifold with pneumatic tubing remains attached to the valve/actuator which then may be pulled out of line.

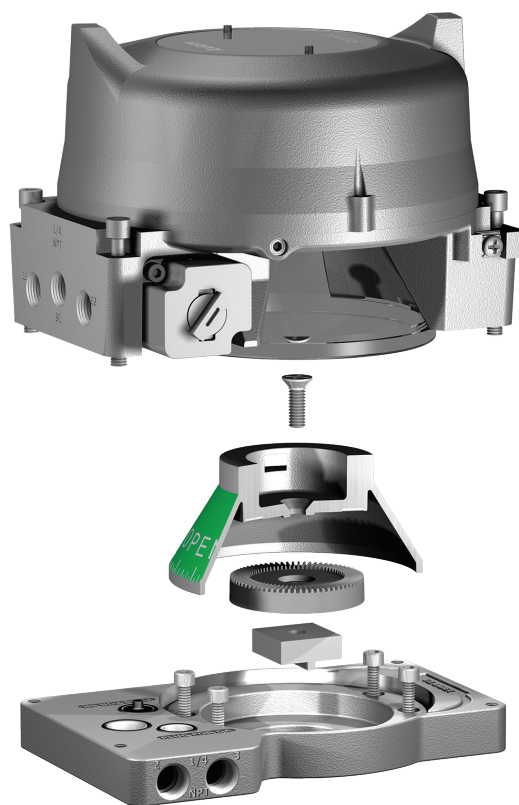
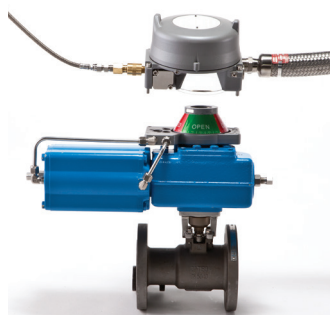

The mounting manifold system is specified and sold separately. Kits are specific to actuator manufacturer. For kit numbers visit: [StoneL.com/mounting](http://StoneL.com/mounting).

## Single or double-acting configuration

The same Axiom model is suitable for both single-acting/spring return (SR) and double-acting (DA) actuators. The standard rebreather capability for single-acting/spring return is built in. Field configuration may be made by conveniently removing and reinserting the plug for the appropriate actuator type. For rebreather to function properly, both manifold ports must be tubed to the actuator.

Spring return actuator

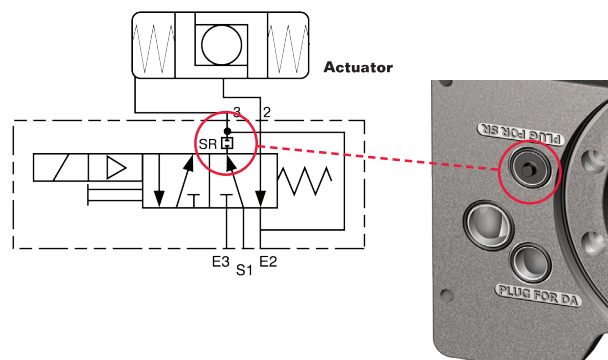

Double-acting actuator

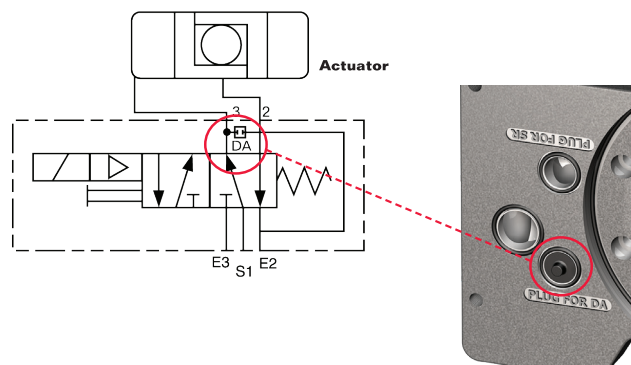

# Sensing and communication module

## Overview

The Axiom platform has all position sensing, communication or switching integrated into StoneL's C-module. Users may set position switches conveniently and accurately on all modules. And easy to view instructions, along with LED indication, are boldly displayed on the module itself.

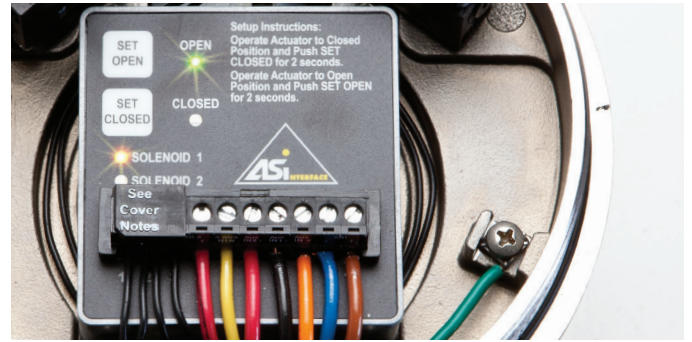

Switching and sensor specifications		Wiring diagram	
<b>SST switching sensors (33)</b>		<b>(33)</b>	<b>(35)</b>
Configuration	(2) 2-wire solid state switches (NO) (1) or (2) Solenoid power inputs	<b>SST</b>	<b>SST 240V</b>
Operation	Normally open (solid state)	<b>Single solenoid</b>	
Maximum current continuous	0.10 amps		
Minimum on current	2.0 mA	<b>Dual solenoid</b>	
Maximum leakage current	0.5 mA		
Voltage range	20 - 125 VAC/125 VDC		
Maximum voltage drop	6.5 volts @ 10 mA; 7.0 volts @ 100 mA		
Short circuit	Protected from direct application of up to 125 VAC/VDC		
Solenoid input	22 - 130 VAC/VDC		
<b>SST switching sensors (35)</b>			
Configuration	(2) 2-wire solid state switches (NO) (1) or (2) Solenoid power inputs		
Operation	Normally open (solid state)		
Maximum current continuous	0.10 amps		
Minimum on current	2.0 mA		
Maximum leakage current	0.5 mA		
Voltage range	20 - 250 VAC; 8 - 250 VDC		
Maximum voltage drop	6.5 volts @ 10 mA; 7.5 volts @ 100 mA		
Short circuit	Protected from direct application of up to 125 VAC/VDC only		
Solenoid input	20 - 250 VAC; 20 - 60 VDC		
<b>NAMUR sensors (44)</b>		<b>Specify solenoid option _H</b>	
Configuration	(2) NAMUR sensors (EN 60947-5-6; I.S.) (1) or (2) Solenoid power inputs	<b>Wiring diagram</b>	
Operation	Normally closed NAMUR sensors (solid state)	<b>(44)</b>	
Current ratings	Target on I < 1.0 mA Target off I > 2.1 mA	<b>NAMUR</b>	
Voltage range	7 - 24 VDC	<b>Single solenoid</b>	
		<b>Dual solenoid option also available but not shown.</b>	
		<b>Specify solenoid option _E</b>	

# Sensing and communication module

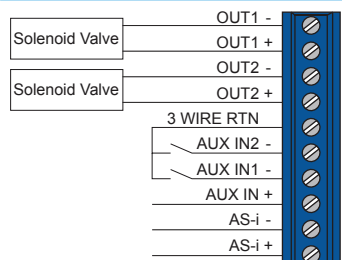
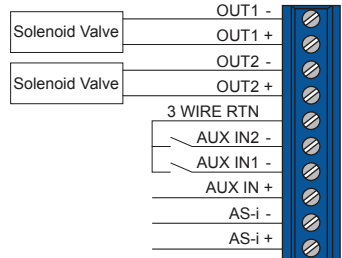
Valve Communication Terminal (VCT) specifications	
<b>AS-Interface (96)</b>	
Configuration	(2) Discrete sensor inputs (2) Auxiliary discrete inputs (2) Power outputs (solenoids)
Maximum current	160 mA, both outputs combined
Auxiliary inputs	24 VDC @ 2 mA (self-powered)
Outputs	4 watts @ 24 VDC both outputs combined
Outputs, voltage	21 - 26 VDC
Configuration code	ID=F; IO=4 (4DI/2DO)
AS-i version	3.0
Devices per network	31
<b>Wiring diagram (96)</b>  <p>Specify solenoid option _D</p>	
<b>AS-Interface VCT with extended addressing (97)</b>	
Configuration	(2) Discrete sensor inputs (2) Auxiliary discrete inputs (2) Power outputs (solenoids)
Maximum current	100 mA
Auxiliary inputs	24 VDC @ 2 mA (self-powered)
Output	2 watts @ 24 VDC
Output voltage	21 - 26 VDC
Configuration code	ID=A; IO=7 (4DI/2DO)
AS-i version	3.0
Devices per network	62
<b>Wiring diagram (97)</b>  <p>Specify solenoid option _D</p>	

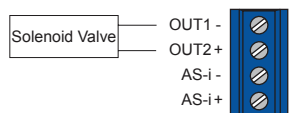
Valve Communication Terminal (VCT) with diagnostics	
<b>AS-Interface (96) with diagnostics (D)</b>	
Configuration	(2) Discrete position sensor inputs (1) Low air supply pressure input (1) Stuck valve/actuator input (2) Remote sensor settings (1) Power output (solenoid) (1) Wink feature (1) Parameter bit spring to open/close (1) Peripheral fault bit (bad coil or stuck spool)
Maximum current	< 50 mA
Output	0.5 watt @ 24 VDC
Outputs, voltage	24 VDC
Configuration code	ID=F; IO=7 (4DI/4DO)
AS-i version	3.0
Devices per network	31
<b>Wiring diagram (96) with diagnostics (D)</b>  <p>Specify solenoid option 1D</p>	

## Sensing and communication module continued

### Valve Communication Terminal (VCT) specifications

#### Foundation Fieldbus VCT, bus powered (93)

Configuration	(2) Discrete sensor inputs (2) Power outputs (solenoids) Multiple DI/DO blocks or modified output block
Outputs	2 mA @ 6.5 VDC each; current limited to 2 mA (bus powered)
Devices per network	Max of 16 devices recommended

**Wiring diagram (93)**

Specify solenoid option \_A

### Valve Communication Terminal (VCT) with diagnostics

#### HART (71) with diagnostics

Local indication LEDs	Valve open, valve closed, solenoid power
Special configuration attributes	Remote sensor settings Wink
Local diagnostic LEDs	High/low air pressure Stuck valve/actuator Bad coil Stuck spool/pilot
Position feedback	
Current output	4-20 mA
Voltage	14 - 35 VDC (24 VDC nominal)
Loop resistance	250 ohms (min) to 400 hms (max) at 24 VDC
Pressure accuracy	+/- 1% of full scale
Solenoid power	
Conventional model 1D	0.5 watt (0.02 amp @ 24 VDC)
Intrinsic safety model 1E	0.5 watt (0.04 amp @ 12 VDC)
HART version	7.0

**Wiring diagram (71) with diagnostics (D)**

Specify solenoid option 1D or 1E

### Valve Communication Terminal (VCT) specifications

#### DeviceNet™ (92)

Configuration	(2) Discrete sensor inputs (2) Remote sensor settings (2) Power outputs (solenoids) (1) Wink feature (1) 4-20 mA auxiliary analog input, 10-bit resolution; no additional power source required
Transmission rate	Software selectable 125K, 250K or 500K baud
Messaging	Polling, cyclic and change of state
Outputs	4 watts @ 24 VDC both outputs combined
Outputs, voltage	24 VDC
Other features	Predetermined output fail state

**Wiring diagram (92)**

Specify solenoid option \_D

### Expeditor specifications

#### Expeditor (80)

Position feedback control (AI)	4-20 mA loop, 9 - 35 VDC
Intermediate position control (AO)	4-20 mA loop, 9 - 35 VDC
Position monitoring accuracy	+/- 1° of rotation
Intermediate control accuracy	+/- 3° of rotation
Solenoid voltage	24 VDC (conventional models) 12 VDC (Intrinsic safety models)

**Wiring diagram (80)**

Specify pneumatic valve option 2D or 2E



## Position sensor and module

### Position sensor

The Axiom utilizes a magnetic resistive (Mag Res) sensor system that monitors exact valve position. The Mag Res sensor system is tolerant of lateral and vertical shaft movement which may be experienced in high cycle worn actuators without affecting rotational measurement. No cams, shafts or other mechanical apparatus are required that are prone to wear and binding.

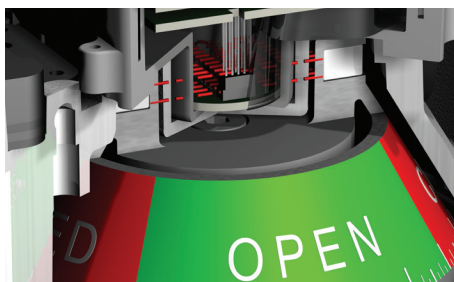

### C-module

Used in the Axiom platform, the C-module (continuous sensing) integrates a magnetic resistive sensor system to monitor exact valve position throughout the rotational range. Push button or remote open and closed position setting along with microprocessor based operation make this state-of-the-art system convenient, reliable, and smart.

### Open and closed settings

Switches correspond to a particular valve position and are set using the push button panel on the module's sealed membrane pad. Simply operate the actuator to the open position (using standard internal manual override) and push the "Set Open" button. Operate the actuator to the closed position and push the "Set Closed" button. Position settings remain locked in when power is removed and reapplied.

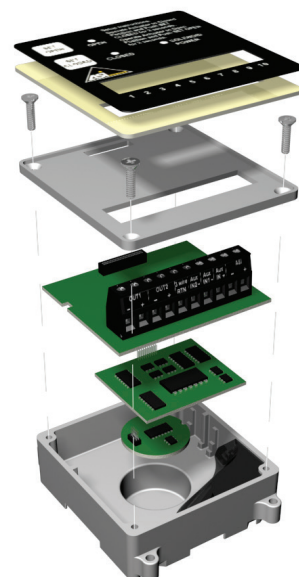

## Visual indicator

### Visual indicator designations

Clearly view valve position status from up to 75 feet with the Axiom's visual indicator. The indicator's rugged Lexan® construction makes it resistant to physical damage and tolerant to most corrosives.

DESIGNATION	0°	90°
R	RED CLOSED	GREEN OPEN
G	GREEN CLOSED	RED OPEN
1		
2		
X	Specialty configuration - please consult factory	

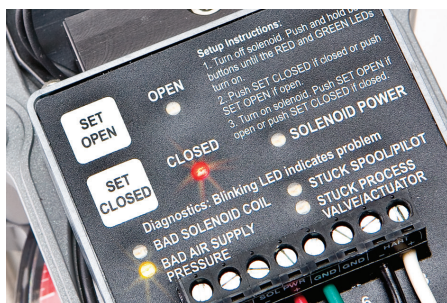

## Diagnostic systems

### Reduce plant downtime and cut maintenance costs

The Axiom AS-Interface and HART models feature on-board diagnostics that predict potential automated valve malfunctions. As a result, plant downtime may be reduced by repairing automated valves during planned shutdowns instead of process operations. Should problems occur during process operation, maintenance personnel will be aided by rapidly locating failure causes, consequently speeding up valve repair and operation renewal.



### Identify potential problems

- Check air supply pressure**  
 Alerts are activated if low or high levels exceed preset thresholds that would threaten pneumatic valve or actuator performance.
- Determine solenoid condition**  
 Voltage and current levels are monitored to determine the health of the solenoid coil whenever energized.
- Local trouble-shooting display**  
 Device LED array identifies problem sources for rapid trouble-shooting and maintenance at the valve/actuator site.
- Monitor pneumatic spool and pilot valve operation**  
 Pneumatic valve spool position is monitored to determine proper shifting performance when the solenoid is energized and de-energized.
- Remote switch setting**  
 Open and closed limit switch settings may be made with on-board push buttons or remotely through the control system.
- Field identify with winking**  
 To positively confirm the field device identity, the control room may initiate the Wink function that flashes both open and closed LEDs without affecting valve operation.
- Stuck process valve/actuator**  
 If the Axiom stalls in mid stroke and no Axiom problem sources are identified an alert will be energized to indicate the problem source is in the valve/actuator assembly.



### Axiom with AS-Interface diagnostics in AX (96)

The AX (96) offers basic diagnostics for AS-Interface network applications that enable end use customers to increase uptime and reduce maintenance costs. Axiom AS-Interface diagnostic systems interface with any version 2.1 or greater masters/gateways.

#### Electrical connections

The Axiom with AS-Interface diagnostics uses standard (1-31) addressing with a 4DI/4DO profile to maximize the diagnostic data available via the network. Diagnostic units may be integrated on the same network as other AS-Interface devices.

#### Control system interface

Interface up to 31 Axiom units into your control system. Communication bits may be mapped into standard DCS or PLC as desired. No special software is required. See the StoneL FieldLink program for information about the cost saving benefits and easy installation of the AS-Interface protocol.

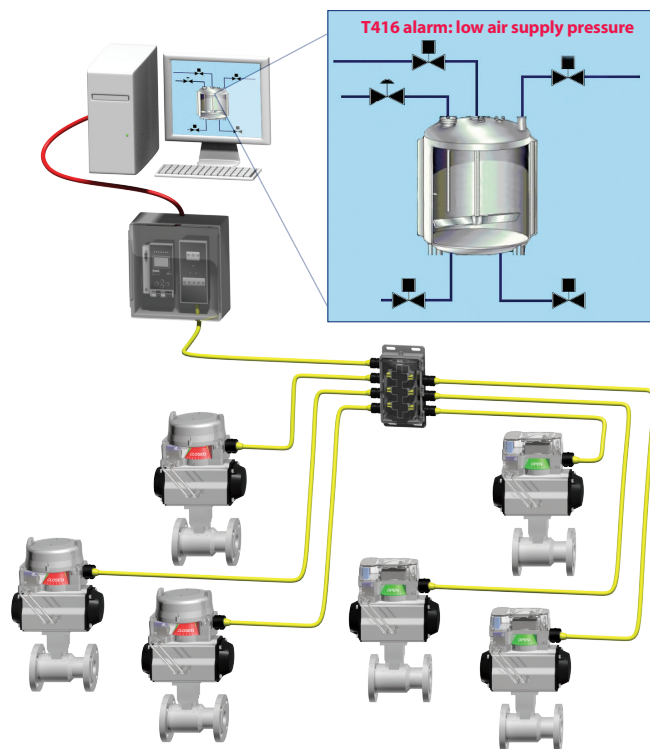



**Axiom with HART in AX (71) features comprehensive predictive diagnostics**

The AX71 is a valve monitoring and control device for discrete quarter-turn automated valves. Used in conventional applications, it has the added capability of providing diagnostic information for the pilot solenoid, spool valve, and actuator. And, the device stores historical data on each open and closed operation.

**Excessive valve torque changes**

Open and closed breakaway actuator differential pressures are measured and compared to baseline levels during each operation. This enables operators to observe unusual pressure/torque level trends, which may ultimately lead to a malfunction.

**Erratic valve/actuator performance**

Total travel time and dead time (time between energizing and initial actuator movement) are measured during each operation, recorded, and compared to the baseline. This gives maintenance staff additional clues on potential automated valve problems.

**Valve/actuator end-stop changes**

Exact valve position is continuously measured and may be used to determine if changes have occurred at end-of-travel. Deviations from zero or span endpoints are graphically portrayed to alert maintenance staff of worn end-stops.

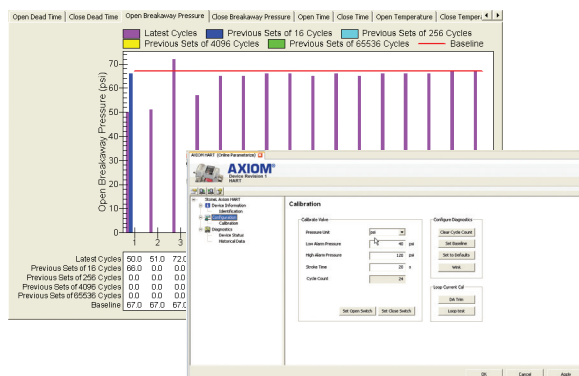

**Easy control system integration**

**System connections**

Two, 2-wire connections attach to the control system to provide discrete solenoid control and continuous position monitoring. A standard 24 VDC discrete output (DO) powers and controls the solenoid valve. Intrinsically safe solenoid pilot may also be selected. A conventional 4-20 mA analog input (AI) provides continuous exact valve position feedback into the control system.

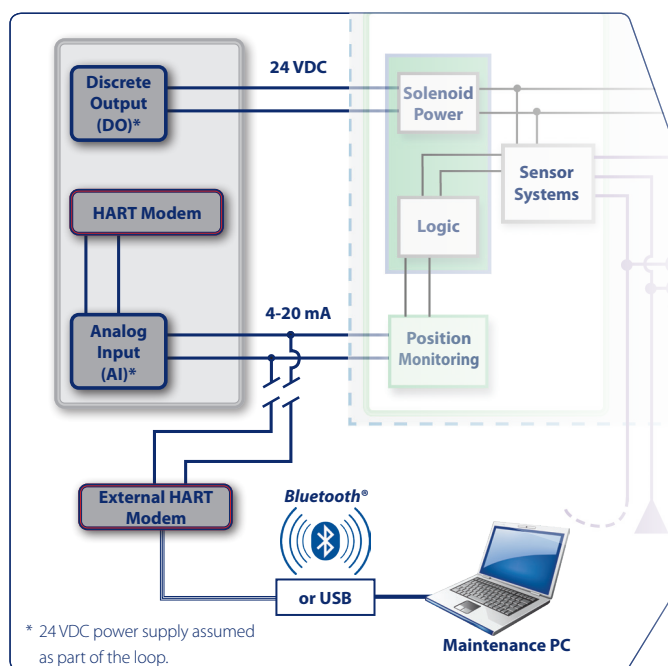

**HART signal**

The HART communication signal is overlaid on the 4-20 mA analog position monitoring input. The signal may be read via internal modem in the DCS system or external modem. External modems may transmit information to a DCS or to a remote PC via a hardwired or a wireless connection.

**Software integration**

Integration to various DCS or asset management systems may be achieved using open, standardized technologies such as enhanced EDDL (Electronic Device Description Language) or FDT/DTM (Field Device Tool/Device Type Manager). Most DCS vendors use one or both of these technologies, which provides open access to device intelligence and allows easy use of all features and benefits available from the Axiom HART device.

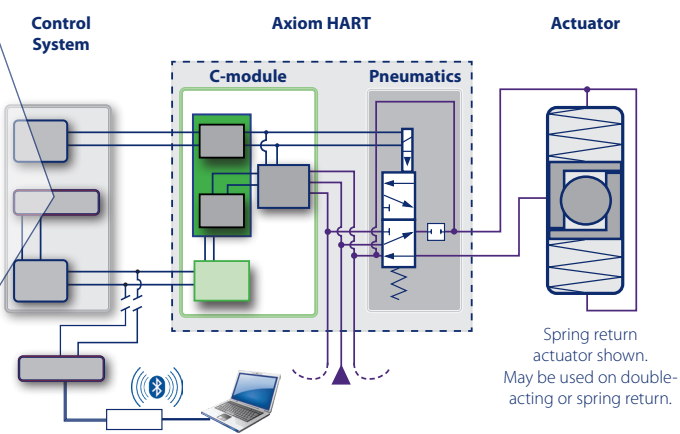

## Axiom Expeditor

### Improve process performance and prevent damage to equipment with intermediate control

With expanded control and monitoring capabilities, the Axiom Expeditor offers unparalleled value in batch processing applications. Below are a few examples of applications where the Axiom Expeditor may improve your plant operation.

#### Fill control

Fill tanks and hoppers rapidly and accurately. You can set the Axiom Expeditor to partially close the valve to reduce flow as the full level approaches. You get fast, economical “topping off” of every batch with a single valve sized for high flow rates, which may be throttled back at the end of the fill cycle.

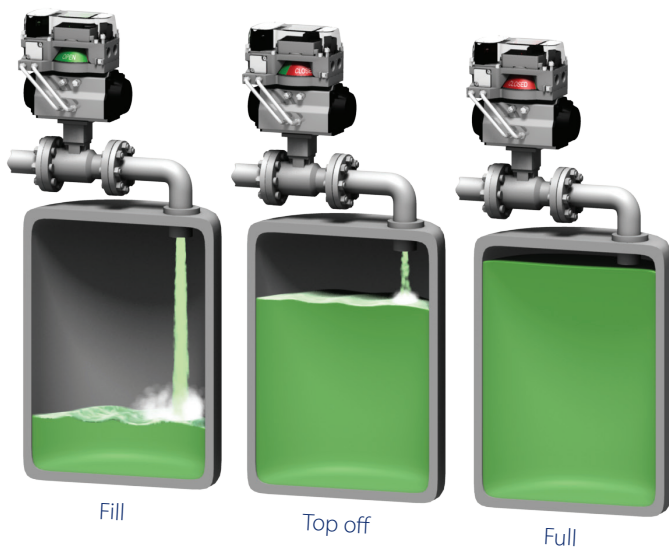

#### Flow dampening

The Axiom Expeditor allows valves to close using multiple steps, which inhibits water hammer resulting from a sudden full closure. You get prolonged valve and piping life, improved process flow performance and less potential for catastrophic failure.

#### Thermal shock reduction

By partially opening a standard discrete valve, steam lines are heated gradually; thus preventing thermal shock. Once lines are heated, full opening may occur minimizing any potential damage to steam lines. This is especially critical in CIP (clean-in-place) and SIP (steam-in-place) applications.

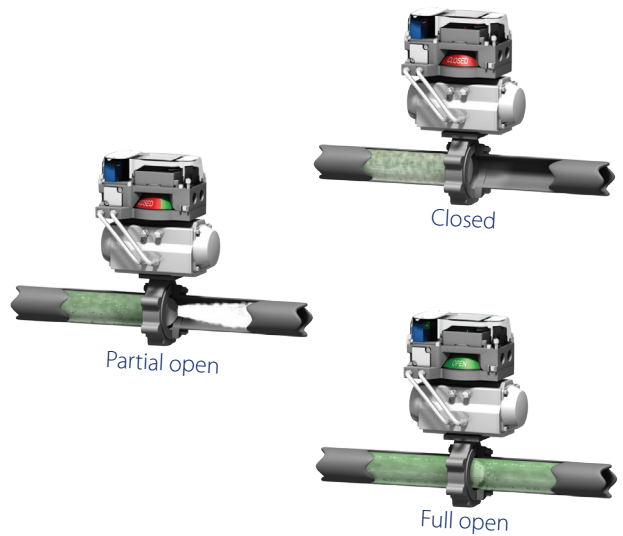

#### Fast, convenient set-up

Calibration may be performed quickly and easily using the Axiom Expeditor’s readily accessible membrane control pad. By simply following the on-board instructions, with the unit powered up, all set-up procedures may be performed in a few easy steps and the actuator evaluated for proper stroke timing.

During set-up, as mentioned above, the Axiom Expeditor automatically gages the speed of the actuator to determine if flow restrictors are needed. If full stroke is less than one second, flow restrictors (included with each Expeditor from the factory) are required to assure smooth, consistent intermediate control operation.

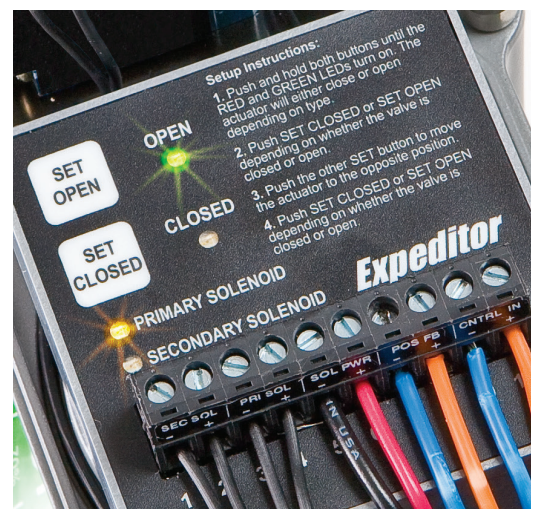

### Simple operation and control system integration

- Full open and closed cycling is performed by energizing and de-energizing the discrete 24 VDC output (DO) from the control system.
- A preset intermediate position may be achieved by maintaining power from the discrete output (DO) and switching on the analog output (AO) at a preset level between 4 and 20 mA.
- Intermediate control is achieved by maintaining power from the discrete output (DO) and energizing the control system's analog output (AO). By changing the AO signal, the Axiom control output will toggle the solenoids to the desired position within  $\pm 4\%$  of full scale.
- The valve/actuator operates to the fail-safe position whenever the discrete output (DO) is de-energized.

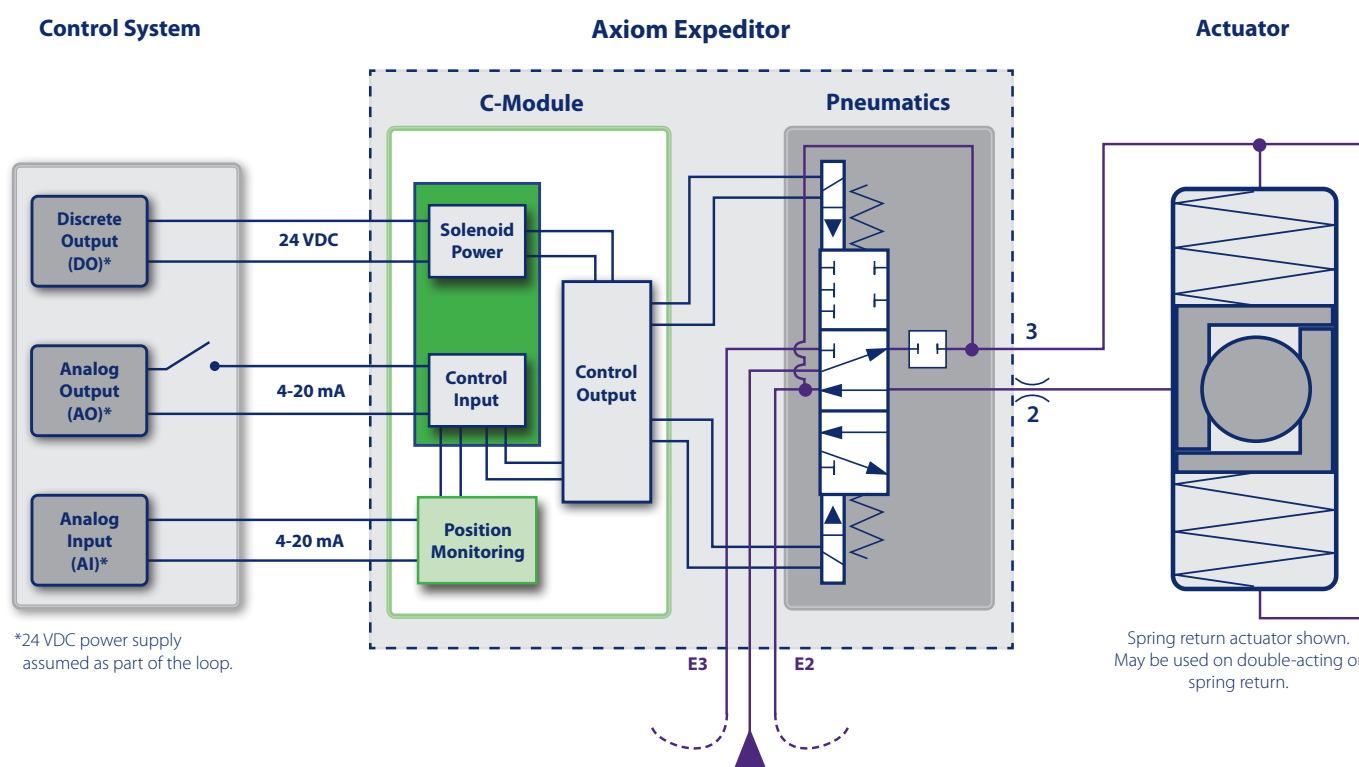

Expeditor specifications	
<b>Expeditor (80)</b>	
Position feedback control (AI)	4-20 mA loop, 9 - 35 VDC
Intermediate position control (AO)	4-20 mA loop, 9 - 35 VDC
Position monitoring accuracy	+/- 1° of rotation
Intermediate control accuracy	+/- 3° of rotation
Solenoid voltage	24 VDC (conventional models) 12 VDC (Intrinsic safety models)
<b>Wiring diagram (80)</b>	
<b>Expeditor</b> Specify pneumatic valve option 2D or 2E	Solenoid Valve      Secondary - Solenoid Valve      Secondary + Solenoid Valve      Primary - Solenoid Valve      Primary + Solenoid Power      Solenoid Power - Solenoid Power      Solenoid Power + 4-20 mA      Position Feedback - 4-20 mA      Position Feedback + Control      Control - Control      Control +

Expeditor specifications	
Cycle life	500,000 cycles (full cycles with intermediate position; cycle life may vary depending on intermediate toggling) Cycle life may be extended by installing solenoid spool service kit.
Temperature rating	-18° to 50° C (0° to 122° F)
Supply pressure	40 psi (2.7 bar) minimum 120 psi (8.2 bar) maximum
Solenoid power	0.5 watt (0.02A @ 24 VDC) 0.5 watt Intrinsically Safe (I.S.) (0.04A @ 12 VDC)

Model selector

**SERIES**

AX Explosionproof

**FUNCTIONS**

**Sensor/switching modules**

33S	SST NO sensor [select pneumatic valve option 1H or 2H]
35S	SST 240 V Universal (NO sensor) [select valve option 1H or 2H]
44S	NAMUR module (EN 60947-5-6; I.S.) [select pneumatic valve option 1E or 2E]
80S	Expeditor [select pneumatic valve option 2D or 2E; available with pneumatic temperature option S only]

**Valve communication Terminals (VCTs)**

71D	4-20 mA HART with diagnostics [select pneumatic valve option 1D or 1E]
92S	DeviceNet™ [select pneumatic valve option 1D or 2D]
93S	Foundation Fieldbus (bus powered; I.S.) [select pneumatic valve option 1A or 2A]
96S	AS-Interface [select pneumatic valve option 1D or 2D]
96D	AS-Interface with diagnostics [select pneumatic valve option 1D]
97S	AS-Interface with extended addressing [select pneumatic valve option 1D or 2D]

**PNEUMATIC VALVE**

**Single pilot**

1H	Universal voltage solenoid
1D	0.5 W 24 VDC solenoid
1E	12 VDC I.S. solenoid
1A	Piezo

**Dual pilot**

2H	Universal voltage solenoid
2D	0.5 W 24 VDC solenoid
2E	12 VDC I.S. solenoid
2A	Piezo

**PNEUMATIC OVERRIDE / CV**

**For single pilot**

N	Internal momentary override only / 0.7 Cv
M	External momentary & internal override / 0.7 Cv
L	External latching & internal override / 0.7 Cv
E	Internal momentary override only / 1.2 Cv
Y	External momentary & internal override / 1.2 Cv
G	External latching & internal override / 1.2 Cv

**For dual pilot**

N	Internal momentary override only / 0.7 Cv
M	External momentary & internal override / 0.7 Cv
L	External latching & internal override / 0.7 Cv
E	Internal momentary override only / 1.2 Cv
Y	External momentary & internal override / 1.2 Cv
G	External latching & internal override / 1.2 Cv

**PNEUMATIC TEMPERATURE**

**For single pilot**

S	Standard
T	Extended [select pneumatic valve option _H, _D, or E]

**For dual pilot**

S	Standard
T	Extended [select pneumatic valve option _H, _D, or E]

**ENCLOSURE**

**Epoxy-coated aluminum**

A	North American (NEC/CEC)
V	International (IEC)
L	Brazilian

**Stainless steel**

S	North American (NEC/CEC)
T	International (IEC)
M	Brazilian

**CONDUIT/CONNECTORS**

02	(2) 3/4" NPT
05	(2) M25

**VISUAL INDICATOR** [see chart on page 9]

RA	Red closed/green open	1A	Three-way 1	XA	Special
GA	Green closed/red open	2A	Three-way 2		

Model number example

AX 96S 1D L S A 02 RA

**MODEL NUMBER**

**OPTIONAL**

**PARTNERSHIP ID**

Mounting hardware required and sold separately.

Some models may include 5-digit identification suffix.

Specifications	
<b>Materials of construction</b>	
Housing and mounting manifold	Epoxy-coated anodized aluminum or 316 stainless steel
<b>Visual indicator</b>	
Drum	Polysulfone
Lens	Lexan® polycarbonate
Fasteners and mounting adaptors	316 stainless steel
Pneumatic valve	See pneumatic valve specifications on page 4.
<b>Temperature ratings (pneumatic valve dependent)</b>	
Piezo pilots (_A)	-10° to 60° C (14° to 140° F)
Solenoid pilots _D, _E and _H	<b>0.7 Cv</b> -18° to 50° C (0° to 122° F) <b>1.2 Cv</b> -10° to 50° C (14° to 122° F)
Standard (S)	-18° to 50° C (0° to 122° F)
Extended (T)	-40° to 80° C (-40° to 176° F) Consult factory
<b>Position sensor system</b>	
Accuracy	Within 1°
Repeatability	Within 1°
Setting buffer	4° from setpoint Rotational distance from original setpoint where switch will energize on return stroke.
Dead band	6° from setpoint Rotational distance from original setpoint where switch will de-energize.
Maximum rotational range	120°

<b>Operating life</b>	
Pneumatic valve	1 million cycles Cycle life may be extended by installing solenoid spool service kit.
<b>Warranty</b>	
Mechanical components (pneumatics included)	Five years
Electronic components	Five years
<b>Ratings</b>	
Explosionproof (Ex d, Zone 1 or Class I and II, Div. 1)	AX models*
Nonincendive (Ex n, Zone 2 or Class I and II, Div. 2)	AX models*
Intrinsically safe (Ex ia, Zone 0 or Class I and II, Div. 1)	Functions 44 and 93*
<b>Enclosure protection</b>	
Type 4, 4X	All models
Ingress Protection 66 and 67	All International models (enclosure options V or T)
<b>Approvals*</b>	
See <a href="http://Stonel.com/approvals">Stonel.com/approvals</a>	
* Only models listed on Stonel's official website are approved per specific rating.	

Dimensions

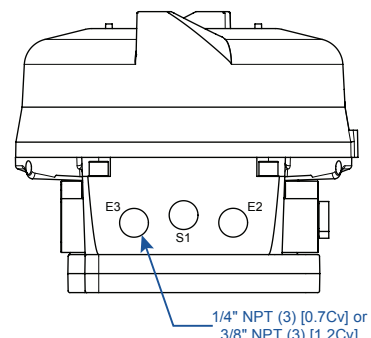
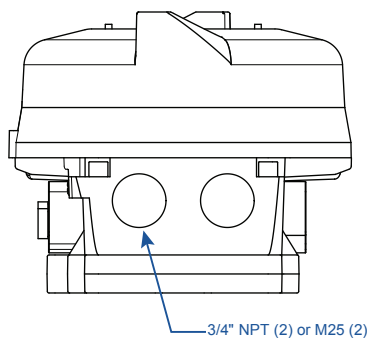
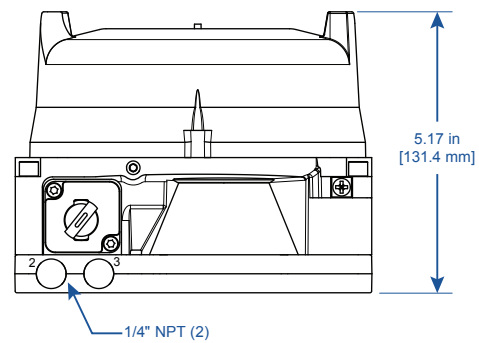
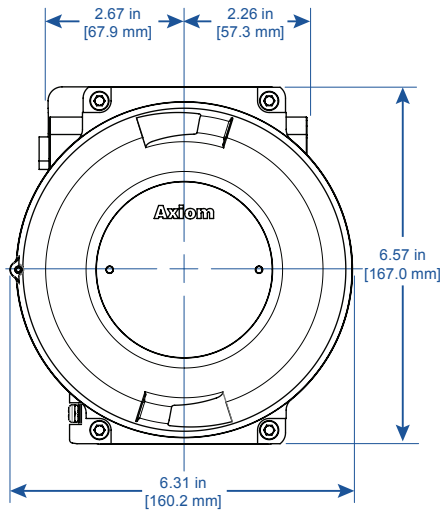



26271 US Highway 59, Fergus Falls, MN 56537 USA  
Tech hotline +1 218 737 0701  
Tel. +1 218 739 5774  
Email: [sales@stoneL.com](mailto:sales@stoneL.com)

**StoneL.com**

Publication Number  
S-912-12/20

Subject to change without prior notice. Neles, Jamesbury and Easyflow by Neles, StoneL, and certain other trademarks, are either registered trademarks or trademarks of Neles Corporation or its subsidiaries or affiliates in the United States and/or in other countries. For more information [www.neles.com/trademarks](http://www.neles.com/trademarks)