

3-weg-kogelkraan type 285 PVC-U horizontaal/L-boring - DA (dubbelwerkend) zonder handbediening met lijmmof, metrisch

uitvoering:

- voorzien van pneumatische aandrijving PA11 (DN10/15-25), PA21 (DN32-50)
- basispositie A-C geopend, geactiveerde positie B-C geopend, zie stroomschema
- steltijd 90°< 1-3 s
- radiaal in- en uitbouwbaar
- geïntegreerde draadbussen (inserts) voor de bevestiging van de afsluiter

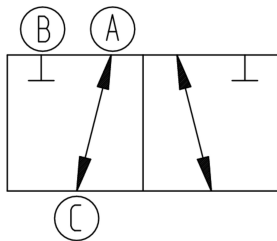
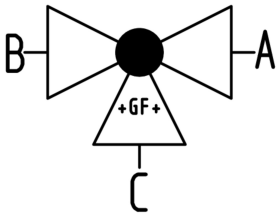

d (mm)	DN (mm)	PN (bar)	kv-waarde ($\Delta p=1$ bar) (l/min)	EPDM Code	SP gewicht (kg)	FKM Code	SP gewicht (kg)
16	10	10	50	199 285 202	1	0,925	199 285 212
20	15	10	75	199 285 203	1	0,931	199 285 213
25	20	10	150	199 285 204	1	1,059	199 285 214
32	25	10	280	199 285 205	1	1,183	199 285 215
40	32	10	480	199 285 206	1	2,115	199 285 216
50	40	10	620	199 285 207	1	2,452	199 285 217
63	50	10	1230	199 285 208	1	3,806	199 285 218

d (mm)	D (mm)	H (mm)	H1 (mm)	H2 (mm)	H3 (mm)	H4 (mm)	H5 (mm)	H6 (mm)	L (mm)	L1 (mm)	L2 (mm)	L3 (mm)	L4 (mm)	L5 (mm)	L6 (mm)
16	50	159	28	62	97	40	77	8	109	194	73	36	25	261	76
20	50	159	28	62	97	40	77	8	112	194	73	36	25	261	76
25	58	168	32	71	97	40	77	8	131	194	86	43	25	261	76
32	68	168	36	71	97	40	77	8	151	194	99	50	25	261	76
40	84	203	45	84	119	51	99	9	181	224	120	60	45	305	95
50	97	203	51	84	119	51	99	9	205	224	137	69	45	305	95
63	124	225	65	106	119	51	99	9	261	224	179	89	45	305	95

d (mm)	L7 (mm)	M	z (mm)	z1 (mm)	inch bena- dering (inch)
16	48	6	81	40	3/8
20	48	6	81	40	1/2
25	48	6	94	47	3/4
32	48	6	107	54	1
40	59	8	130	65	1 1/4
50	59	8	143	72	1 1/2
63	59	8	185	92	2

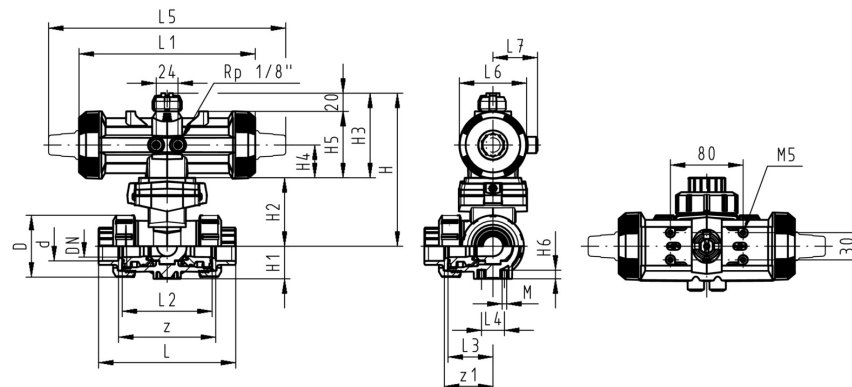

Specificatieblad



valid from: 3-8-17

De technische gegevens zijn niet bindend en houden geen garanties in van eigenschappen. Wijzigingen voorbehouden. Onze algemene verkoopvoorwaarden zijn van toepassing.

Georg Fischer Piping Systems Ltd, Postfach, CH-8201 Schaffhausen/Switzerland

Phone +41 -(0)52-631 1111

e-mail: info.ps@georgfischer.com

Internet: <http://www.gfps.com>